

Norwegian Curling Association

Concept Curling Rink

Technical and financial advice for building a curling rink

March 2007

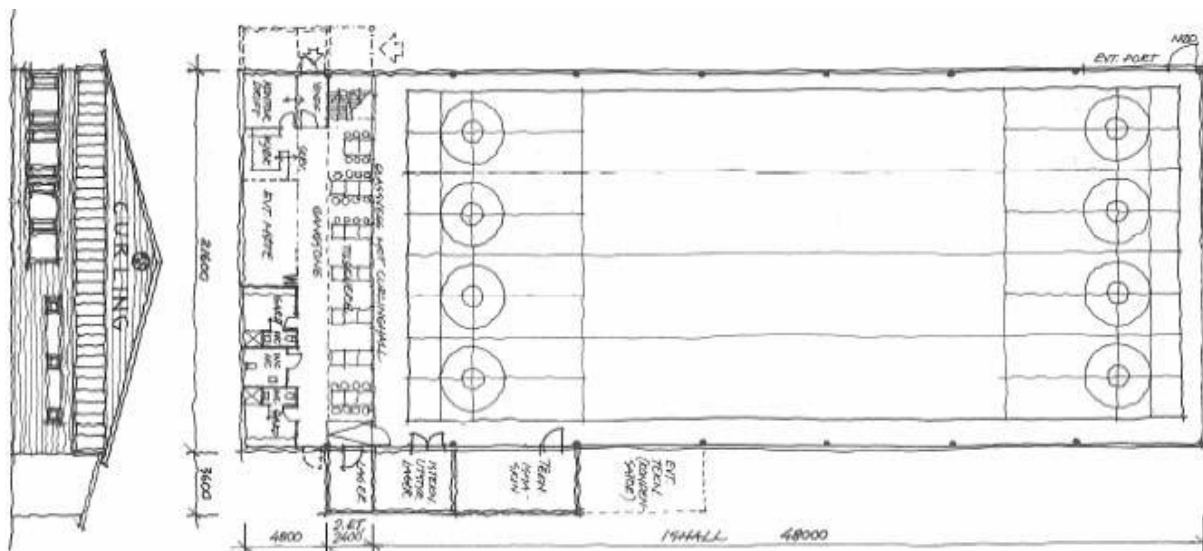

COWI

COWI AS
Grensev. 88
Postboks 6412 Etterstad
0605 Oslo Norway
Phone +47 02694
www.cowi.no

RAMSFJELL ARKITEKTER AS
SIV. ARK. MNAL • INT. ARK. MNIL

KRONPRINSENSGT. 3, 0251 OSLO

TELEFON 22 83 28 00 - FAX 22 83 18 46

ORG. 988 464 767

www.ramsfjell.no



Norwegian Curling Association

Concept Curling Rink

Technical and financial advice for building a curling rink

Prepared by Bent Ramsfjell

Verified by Stig Mathisen

Approved by Morten Tveit

Original document published on 22/03/2007



DISCLAIMER

This document has been produced by the Norwegian Curling Association/Norges Curlingforbund (NCF). The World Curling Federation (WCF) has been given permission to use this document as a reference for its Member Associations and has decided to translate it into English. It is a direct translation from Norwegian, however the WCF believes it is a good first assistance for clubs that are planning to build a curling rink. The next step for the WCF will be to produce a new document and international handbook on "How to Build a Curling Rink".

The WCF is not responsible for the any of the content of this report.

This document has been translated by Leif Öhman, John Burns and Bent Ramsfjell

(Exchange rate 2010-11-26 1€ = approx. 8.15 NOK)

Preface

Curling is a growing sport in Norway. Good performances in international championships have contributed to a marked interest in curling. In particular, the Olympic gold medal in Salt Lake City has meant that curling now has a larger space on the 'map of Norway'.

There is still great potential for curling in Norway to grow more. Experience from places which have curling facilities suggests that facilities and clubs are needed to create viable local curling environments. *The biggest limitation on the growth of curling in Norway is the lack of dedicated facilities.* It is not that there is a lack of interest in building curling rinks, but technical and economic uncertainty have prevented the fulfilment of these development plans.

We think that the Norwegian Curling Association (NCF) should do something. Therefore, we have prepared this report as a manual for what is needed to build and operate a curling facility. It contains technical and financial guidance and is intended as an aid to potential developers and a 'catalyst' for the realization of plans for curling rinks.

The report on a "Concept Curling Rink" will be a key element in NCF's policy plan for curling facilities for the period 2007-2011. The construction policy plan will target local government and local sports clubs and will have a strong focus on establishing more curling rinks.

To create the report, the Norwegian Curling Association received the help of an engineering and consultancy company - COWI and Ramsfjell Architects. The work of the brothers Eigil and Bent Ånund Ramsfjell has been central to this report - there are few who have visited more curling rinks. In addition, Stig Mathisen, Frode Fjeldstad and Sverre Sandbakken have been key technical contributors. Ole Ingvaldsen from Curlingbaner has contributed his experience from the development and operation of the Snarøya Rink.

The message from the Norwegian Curling Association is: *Build more curling rinks - now! Curling is a sport for life.* I hope that more and more Norwegians will get to experience this!

Oslo, 22 March 2007

Morten Tveit

NCF President



Table of Contents:

Summary	5
1. Introduction	8
1.1 Background	
1.2 Purpose	
1.3 This report	
2. Description of current situation	10
2.1 Curling rinks in Norway	
2.2 Foreign experiences	
3. Concept Curling Rink	14
3.1 Design	
3.2 Architecture	
3.3 Technical reviews	
4. Economics	28
4.1 Investment costs	
4.2 Operating costs	
4.3 Financing	
5. Solutions for co-location	37
Appendices	38

Summary

Background and Purpose

This report gives technical and financial advice on establishing a curling facility. The report outlines three possible ways in which a curling rink can be designed. It covers the technical challenges and the economic consequences associated with the construction of a curling rink.

A Dedicated Facility

In preparing the Concept Curling Rink we chose to focus on three principal solutions to create dedicated ice for curling. All three have different rink sizes. The solutions include:

- A. Concept Rink 2 sheets
- B. Concept Rink 2+2 sheets
- C. Concept Rink 4 (6) sheets

Our choice of an even number of sheets is not random. Even numbers give better use of the sheets than odd numbers. Rinks with 2+2 sheets are better adapted for cooperation with other ice sports (such as skating, ice hockey and figure skating).

The Concept Curling Rink is based on the principles of 'access for all', so an elevator is required if several floor levels are involved.

The focus is on developing standardized solutions, which are still flexible with a high degree of customization. The aim is to reduce the risk and uncertainty associated with the establishment of a new curling facility. Any new curling facility must be planned and treated individually. Local conditions will always require local adaptations and solutions.

Building components of a Curling Rink

In principle, a curling rink consists of two building elements:

- 1 The ice area
- 2 Technical and social spaces

Area Requirement

Architectural plans for the three rink solutions show the minimum solutions for room sizes. Areas needed for the rink solutions are shown here:

AREA	Area m2		
	2 sheets	2+2 sheets	4 sheets
Ice Rink	480-530	960-1050	960-1050
Social Rooms	100-200	200-300	200-300
Technical Rooms	30-50	30-50	30-50
Total	610-780	1190-1400	1190-1400

Technical Reviews

The major challenges of the construction of a curling rink are primarily related to building engineering and HVAC (Heating, Ventilation and Air Conditioning) facilities. The rink must meet strict requirements for the floor, insulation, ventilation, heating and refrigeration- these are key factors in achieving a 'high class' curling rink.

Investment costs

Investment costs for a curling rink can be divided into fixed costs and 'curling-specific' costs. The total construction costs for the various Concept Curling Rink solutions are shown in Table S.2. (Assumptions are described in Section 4.1)

Cost calculation		2 sheet Rink	2+2 sheet Rink	4 sheet Rink
Description		NOK	NOK	NOK
0	MARGIN & RESERVE	1 114 713	1 763 443	1 739 639
1	COMMON COSTS	896 793	1 418 699	1 399 549
2	BUILDING	5 080 000	8 130 000	8 380 000
3	HVAC SYSTEM	2 700 000	4 654 000	4 212 500
4	ELECTRICAL	578 978	744 040	744 040
5	TELECOMS & AUTOMATION	108 950	158 950	158 950
6	OTHER INSTALATIONS (elevator)	500 000	500 000	500 000
0-6	BUILDING COST	10 979 434	17 369 132	17 134 678
7	OUTDOOR WORK COSTS	0	0	0
0-7	CONTRACTOR COSTS	10 979 434	17 369 132	17 134 678
8	GENERAL EXPENSES	1 282 414	2 028 740	2 001 355
0-8	CONSTRUCTION COST	12 261 848	19 397 871	19 136 033
9	SPECIAL EXPENSES	0	0	0
0-9	PROJECT COST - exclu.VAT (rounded up)	12 300 000	19 400 000	19 150 000

Table S.2: Construction costs for different solutions for Concept Curling Rinks.

'Curling-specific' investments amount to approximately 200-400,000 NOK

Operating costs

Running costs for a curling rink will be dependent on a number of factors. The most important element is energy consumption. The annual (300 days) energy cost for a 4 sheet curling rink is estimated at about 260,000 kWh (180,000 NOK). This takes into account the recovery of thermal energy from ice production.

Financing

A concrete financing plan for the establishment of a curling rink is beyond the scope of this document. But in general, appropriate financing solutions for the construction and operation of a curling rink are divided into the following categories:

- Public funding (lottery, municipal funds, support from the NCF / WCF, etc.)
- Club financing (equity, bank loans, membership fees, etc.)
- Private financing (investors)

Financing - Revenue

Rental of the business (for corporate events, etc.) is an important source of revenue for the existing curling rinks in Norway. It is the social rooms in a curling rink which provide a basis for such revenues.

Operating Model

Financing Solutions for a curling rink should be considered in the context of the choice of operating model. Recent operational models for a curling rink have primarily been:

- Club (one or more)
- Operating Firm (Company or equivalent)

Solutions for co-location

This report is focused on curling rinks as independent units (dedicated to curling). Co-location of curling rinks with other sports, however, will often be beneficial. This will create greater diversity of sports, providing a richer sporting environment and have a positive operational impact.

1 Introduction

1.1 Background

The Norwegian Curling Association (NCF) has engaged an engineer and consultant company – COWI, with Ramsfjell Architects as the advisor, to prepare a concept rink for curling in accordance with the requirements of the Norwegian Ministry for Culture (KKD).

The reason for this is that the NCF wants to intensify the work being done on the establishing several curling facilities. NCF and KKD began discussions on this in 2006. KKD requested that NCF prepared the following documentation to satisfy requirements for public support:

1. A Concept Curling Rink
2. A Construction Policy Plan

Concept Curling Rink

The documentation put together for a Concept Curling Rink is a technical and economic guide that describes what it takes to build and operate a curling facility. The report meets KKD's request for drawings for a pre-project stage on a scale of 1:100 or 1:200 showing the activity level and service areas. It also shows a realistic (but not necessarily very detailed) cost estimate which outlines a financing plan and running plan with the budget (revenue and expenditure).

Construction Policy Plan

The Concept Curling Rink will be a key element of NCFs construction policy plan for curling facilities for the period 2007-2011. The NCF Board of Directors has decided that the construction plan be discussed at NCF's general assembly in May 2007.

NCFs Construction Policy Plan should have an overall national perspective. Through the plan, NCF will promote priorities based on where the sport is established and where there is a need for development of a rink. This is mainly based on the identification of established infrastructures which would make it simpler to find funding to establish new curling facilities.

For the NCF it is especially important to look closely at the places where indoor skating rinks already exist, or new installations are planned in order to exploit shared energy resources. This means that the NCF will work closely with the Norwegian Ice Hockey Federation and similar bodies.

1.2 Purpose

3 principal construction solutions

In the preparation of the Concept Curling Rink we focus on three different construction solutions with dedicated ice for curling:

- A. Concept Rink 2 sheets
- B. Concept Rink 2+2 sheets
- C. Concept Rink 4 (6) sheets

There is a focus on developing standardized solutions which are flexible and can be customised. Any new curling facility must be planned and treated individually - local conditions will always require local adaptations and solutions. The aim is to reduce the risk and uncertainty associated with the establishment of a new curling facility.

Target groups

The target groups for this report are primarily:

- Norwegian Curling Association (NCF)
- Public administration (KKD, municipalities, etc.)
- Regional Sports and other sports bodies (including Norwegian Ice Hockey Federation)
- Sports / clubs / associations
- Potential developers of sports facilities

1.3 This report

Content

- **In Chapter 2** we give a brief description of the current situation for curling facilities in Norway. We also highlight some foreign examples.
- **In Chapter 3** we give three concrete Concept Rink solutions for curling. We focus on the technical facilities required and the demands made on them.
- **In Chapter 4** we give a cost estimate for the construction and operation of the pre-project level (based on the experience of the Snarøya curling rink) We also describe the possibilities for different funding solutions.
- **Chapter 5** includes some examples of co-location of curling rinks in combination with other sports.
- **Appendices** include architectural drawings of the three specific Concept Curling Rink solutions (scale M = 1:200). We also include drawings of some of the examples of other curling rinks at home and abroad.

2. Description of current situation

2.1 Curling rinks in Norway

2.1.1 Introduction

About Curling

Curling is a sport with its roots dating back to the 1500s in Scotland. In Norway, curling was introduced in the 1950s in the winter sport resorts of Geilo and Oppdal.

Curling is a team game which takes place on ice. The international slogan is '*Curling – a sport for life!*' Curling is an activity that can be played by all, regardless of age, gender and physical handicap.

2.1.2 Existing facilities

Originally, curling was played on outdoor rinks. Today, curling is played almost exclusively in ice rinks dedicated to curling. In Norway, there are currently 5 such curling rinks (as of 2007) - at the following locations:

Rink (Location)	Sheets	Year Built	Comment
Bygdøy	2	1972	
Snarøya	4	1978	Expanded to 6 sheets in February 2007
Lillehammer	1	1988	
Oppdal	4	1996	2+2 sheets separated by a walkway
Halden	3	2001	Planned expansion to 5 sheets

Table 2.1: Curling rinks in Norway (existing facilities – as of 2007).

The curling rinks in Bygdøy, Snarøya and Oppdal are dedicated to curling. Appendices 4 and 5 show drawings of the curling rinks at Snarøya and Oppdal respectively. The curling rinks in Lillehammer and in Halden are shared with skating rinks. In Lillehammer the curling rink runs parallel to the length of the ice in Kristin's rink and is physically separated by "penalty boxes". In Halden, the curling sheets are placed across the width of Comet's rink. The curling rink in Halden is shown in Figure 2.1.



Figur 2.1: Curlinghall i Halden.

Sharing Existing Facilities

As well as facilities dedicated to curling, there are other places in the country (including Trondheim, Bergen, Skien, Stavanger) where curling shares ordinary indoor skating rinks with other sports, particularly hockey and figure skating.

2.1.3 Planned construction

Several new curling rinks are planned elsewhere in Norway including Loddefjord (Bergen), Bjugn (integrated in the new ice rink for Lengdeløp), Jar / Stabekk, Nærbø, Kristiansand, Stavanger, Trondheim, Narvik, Tromsø, Kirkenes, Larvik and Tønsberg.

Figure 2.2 illustrates the new ice skating rink in Bergen (to be completed in 2007). This facility includes a 3-sheet curling rink which will be located across the width of the ice rink. The plan in Bergen has many similarities to the curling rink in Halden.

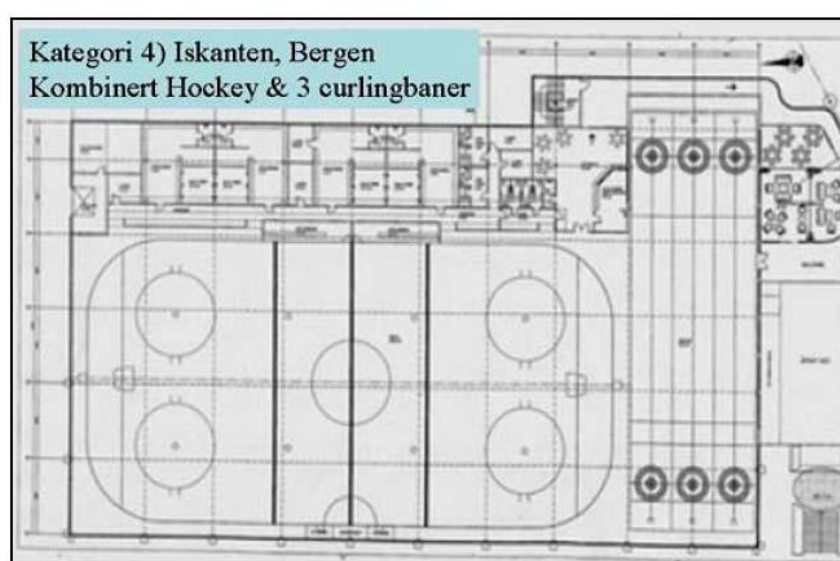

Figur 2.2: Kombinert ishall og curlinghall i Loddefjord, Bergen (ferdig 2007).

2.2 Foreign experiences

Curling rinks abroad

Table 2.2 shows an approximate number of curling rinks and curlers in some other countries (as of March 2007).

Country	Curling rinks (approx)	Players (approx)
Norway	5	3,000
Scotland	28	+10,000
Sweden	36	5,000
Switzerland	48	+10,000
USA	140	16,000
Canada	1200	1,200,000

Table 2.2: Key information about curling in selected comparable countries.

Some examples of different types of curling rinks that are abroad are:

Braehead, Scotland - www.braehead.co.uk An 8-sheet curling rink was built in a shopping complex in Glasgow in 1999. The shopping centre also has an arena with a capacity of 4 to 5,000 people. The World Curling Championships were played there in 2000.

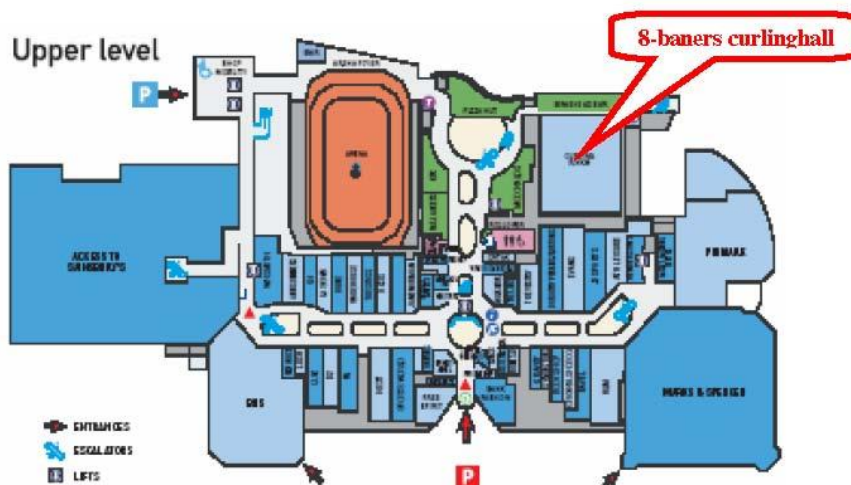

Figur 2.3: Kart over kjøpesenteret Braehead, Skottland, med integrert isarena og curlinghall (8 baner).

Hvidovre, Denmark - www.hcc.dk Soon after the Danish women won the silver medal in the Olympics in Nagano in 1998, two new curling rinks were built in Copenhagen. One is located in Tårnby on Amager (see Appendix 7), while the other is located on the west side of town in Hvidovre. Hvidovre curling rink has 4 sheets and is located in the same complex as another ice rink. The focus here is on energy efficiency.

Bern, Switzerland - www.cba-bern.com In 2001, the exhibition organizer BEA EXPO demolished an existing curling rink to build an exhibition area. The replacement was a brand new 'state of the art' curling rink with 8 sheets and extensive restaurant facilities. The construction cost was approx. 80 million NOK.



Figure 2.4: Allmend Curling Rink, Bern, Switzerland

Landskrona, Sweden - www.curla.nu In Sweden the first private curling rink was completed in November 2004. The rink has 4 sheets. It was built in 6 months. The curling rink is primarily a commercial investment aimed at private business and companies that want to do something extra for customers and employees. If it turns out that the commitment does not give the desired result, the rink is suitable for conversion to other activities.



Figure 2.5: Landskrona Curling Rink, Sweden

Canada - www.curling.ca 1.2 million people curl in Canada. There are about 1200 rinks. 75% of the players are between 25 and 64 years old. 65% are men and 35% are women. In many parts of Canada people farm in the summer and curl in the winter! There are many examples of "country clubs" with a curling rink as part of a wide range of leisure activities (golf, tennis, etc.). Appendix 8 shows an example of a 6-sheet curling rink in Canada.

3. Concept Curling Rink

3.1 Design

In preparing the Concept Curling Rink we chose to focus on three principal solutions to create dedicated ice for curling. All three have different rink sizes. The solutions include:

- A. Concept Rink 2 sheets
- B. Concept Rink 2+2 sheets
- C. Concept Rink 4 (6) sheets

Our choice of an even number of sheets is not random. Even numbers give better use of the sheets than odd numbers. Rinks with 2+2 sheets are better adapted for cooperation with other ice sports (such as skating, ice hockey and figure skating).

Drawings of the Concept Curling Rink solutions

Figure 3.1, 3.2 and 3.3 outline the individual rink solutions. (More detailed drawings of the solutions on a scale of 1:200 are presented in Appendices 1-3). All the drawings show the minimum solution for room sizes. All the Concept Curling Rink solutions are based on the principles of universal access.

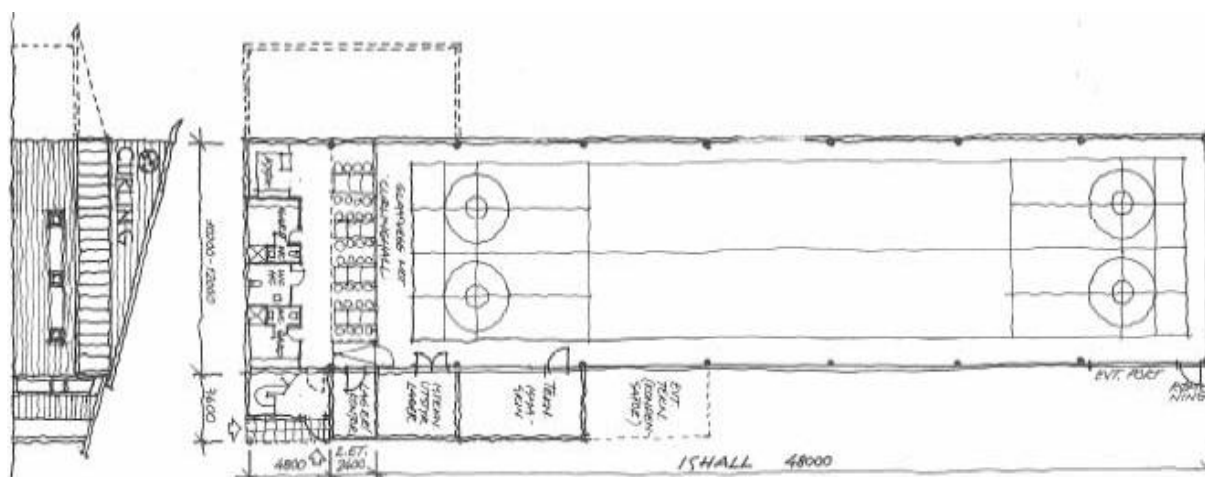

Figure 3.1: Concept Curling Rink 2 sheets.

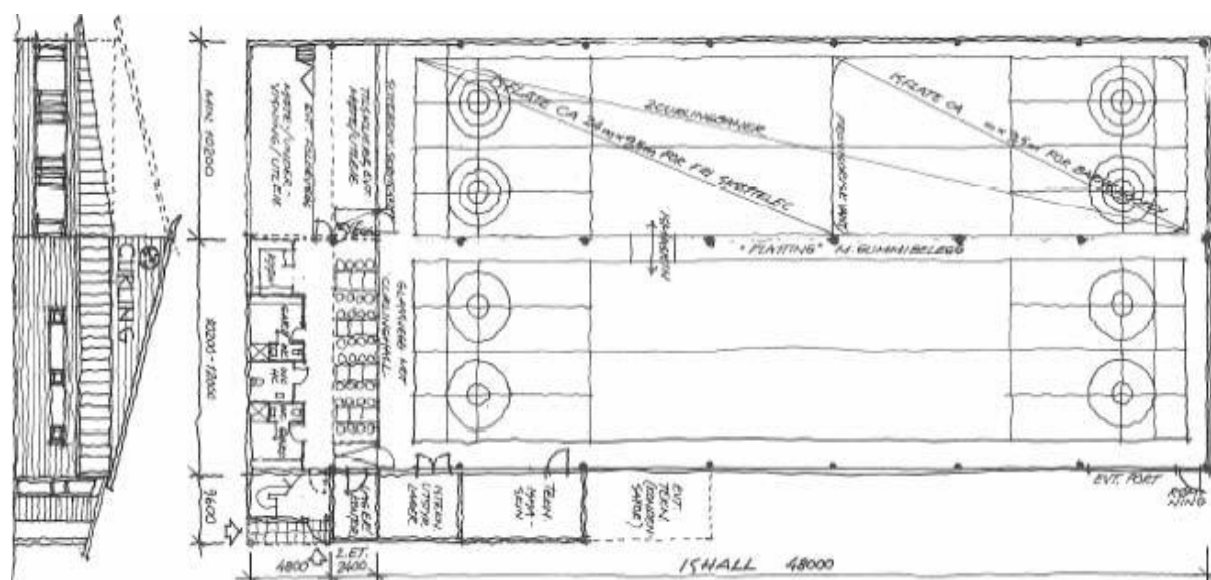

Figure 3.2: Concept Curling Rink 2+2 sheets.

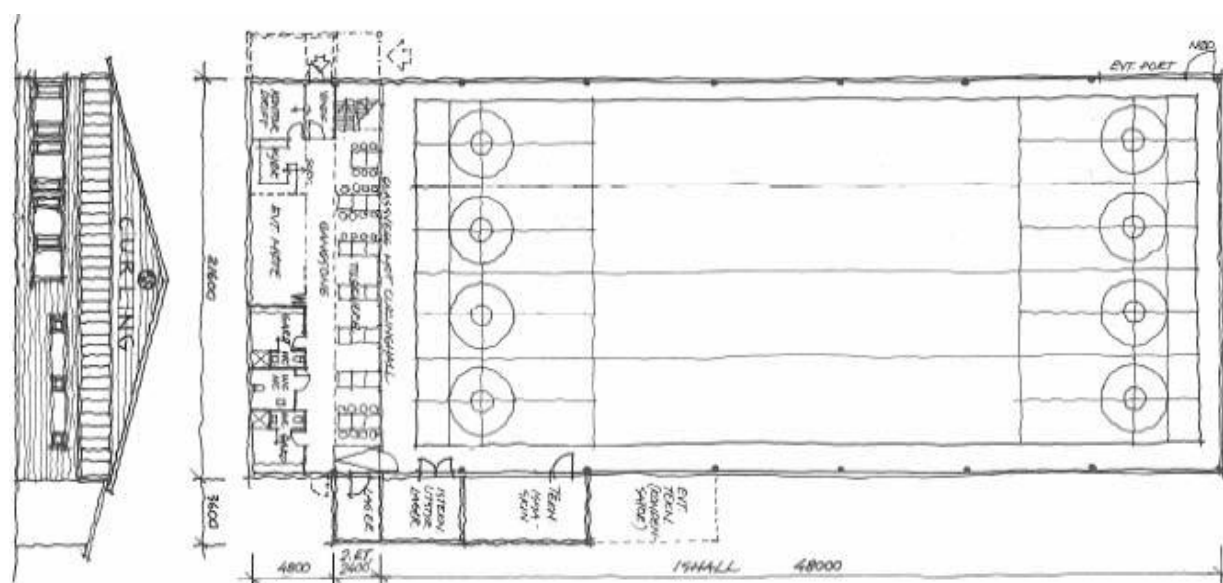

Figure 3.3: Concept Curling Rink 4 (6) sheets.

Building Areas

Each rink solution has two building components in principle:

1. The ice area
2. Technical and social spaces

The ice area

The starting point for the rink concepts is the size of a curling sheet (see Figure 3.4).

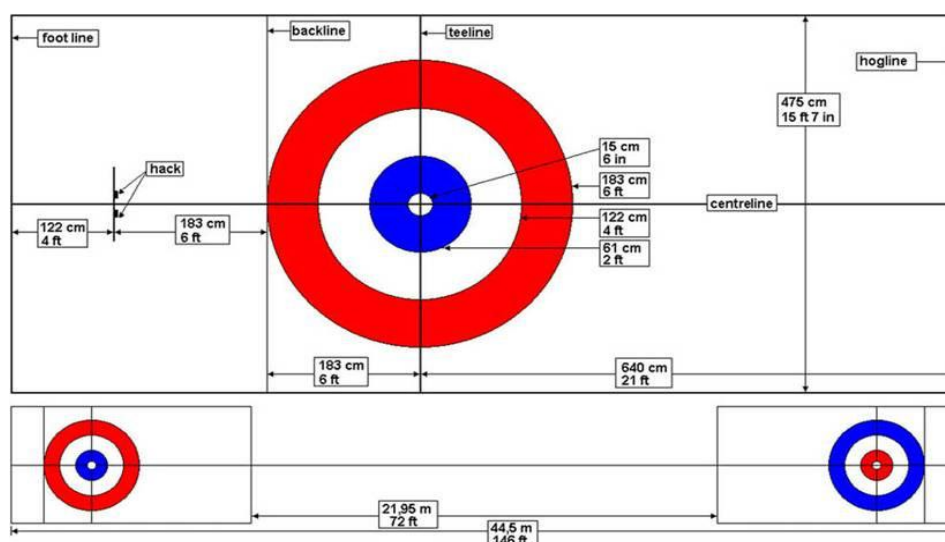

Figure 3.4: A curling sheet **NB: These measurements were revised by the WCF in 2007**

In an ice rink with a capacity for 4 sheets, one can (by building a separation on the ice floor) play curling on one side of the divide and another ice sport on the other side at the same time. (see Figure 3.2).

Cooling pipes in the ice rink should be laid across the width of the surface and not lengthwise.

All rink solutions have space for walking around the ice surface. All rink solutions are based on the principles of universal design and are suitable for disabled athletes (including wheelchair users). If the social areas are on a different level from the ice surface, an elevator will be necessary.

Expansion of playing surface

In March 2007, the World Curling Federation (WCF) decided to enlarge the size of each curling sheet to 45.72 x 5 metres in order to ensure adequate space, for TV production and to simplify ice maintenance.

Other building-related facilities

In addition to the ice rink, the following facilities ('social spaces') are necessary for a curling rink, to a greater or less extent:

- Technical room (engine room, ice making machinery, storage, etc.)
- Locker rooms / Toilets (WC)
- Offices / Conference room
- Kitchen / Cafeteria / Restaurant (catering facilities)

It is the social rooms that provide a basis for operating income by leasing to corporate events, etc.

The Technical Rooms (refrigeration plant, ventilation units) are noisy and best placed separately.

Area Requirements

On the basis of the drawings, the minimum area requirements for the different rink solutions are shown in Table 3.1.

AREA	Area m ²		
	2 sheets	2+2 sheets	4 sheets
Ice Rink	480-530	960-1050	960-1050
Social Rooms	100-200	200-300	200-300
Technical Rooms	30-50	30-50	30-50
Total	610-780	1190-1400	1190-1400

Table 3.1: Minimum area requirements for Concept Curling Rink solutions (m²).

3.2 Architecture

The architectural assessments of the Concept Curling Rink solutions include:

- Technical Conditions Plan
- Site Plan
- Use of materials and construction
- Flexibility
- Environmental considerations

Technical Conditions Plan

The Municipal and/or development plan must be based on the construction of a curling rink.

Site Plan

The architecture of the facility should be in harmony with the environment and be adapted to the local building traditions. Consideration must be given to parking, accessibility, adaptation to terrain and so on.

Use of materials and construction

Architectural design and engineering solutions for a curling rink must be adapted to its location and usage. Building efficiency and flexibility are important. The building should be designed and located so that heat loss, cooling needs and energy consumption are minimized.

The choice of building design, building materials and technical solutions has implications for future management and operation/maintenance. Decisions in the planning phase may impact on the running of the facility. High wear-and-tear resistance, durability, good operating characteristics, good accessibility and low maintenance needs are important criteria in this respect. Environmentally friendly materials should be used.

A curling rink can be built using materials like wood, brick, concrete and steel. In this document it is assumed that the main bearing structure will be steel. The rest of the materials would be decided on a case by case basis.

Flexibility

A curling rink should be planned with emphasis on achieving flexible solutions. One should be aware of opportunities to facilitate possible future extensions/expansions. This is reflected partly in the proposed 4-sheet curling rink which, with relatively simple measures, can be expanded by two sheets.

Environmental considerations

Technical Regulations under the [Norwegian] Planning and Building Act of 1997 emphasize strongly the environmental concerns in relation to the construction of buildings.

The introductory text (§ 8.1) on 'Environment and Health' states that *"The construction activity in all phases, i.e., acquisition, use and abandonment, should be conducted with proper stress on resources and environment otherwise the quality of life and living conditions deteriorate. Materials and products for use in structures of the rink are made with justifiable use of energy and with a view to prevent unnecessary contamination. Ice rinks should be designed and constructed so that little energy is wasted and little contamination occurs in the building life cycle, including demolition"*.

Similarly, the introductory text (§ 8-5) on 'External environment' says that *"Ice Rink buildings should be located, listed, used and abandoned in a manner that causes little impact on the natural environment. [...] Pollution from construction works should be taken away in such a way that no adverse effects result with regard to people's health and hygiene either in or outside the building. Emissions from rinks should not adversely affect plants or animals in the building's surroundings."*

Localization of a curling rink should be considered within the coordinated use of land and transport. It should be arranged so that as much as possible of the traffic to and from the building can be done using public transport, on foot or by bike.

3.3 Technical reviews

The technical assessment related to the construction of a curling rink covers the following areas:

- Construction Engineering
- HVAC System
- Electrical Power

In these descriptions special emphasis is given to identifying the problems of the different disciplines that are important to achieve an optimal operating situation of a curling rink. The main emphasis is on the description of the building, engineering and HVAC system, as these represent the biggest technical challenges and cost for a curling facility. The descriptions are based on NS 3451 (Building Sections Table, 2nd edition May 1988).

Area requirements

Area requirements are a key factor in the technical assessments. In this report, we have previously seen that a curling sheet is about 5 metres wide and 50 metres long. This means that a

4-sheet curling rink alone has an area need of nearly 1000 m². In addition, there are areas for technical and social needs. The height of a curling rink must be adapted to the climate of technical conditions and create natural spatial effects. For a 4-sheet rink this corresponds to about 5-6 metres.

3.3.1 Architectural Engineering

The description of the techniques used for the building includes the following points:

- **21 Base and foundations**
- **22-28 Primary building elements:**
 - The floor: Principles, structure and specific requirements for the design and tolerance.
 - Load-bearing structures: principles, choice of materials, span lengths, etc.

21 Base and foundations

The basis for this description and cost analysis for a Concept Curling Rink includes a building foundation with flooring and foundations. Blasting work or pile-driven foundations are not included.

22-28 Primary building elements

The floor should consist of a base layer of crushed rock and gravel, 100 mm insulation of EPS and 150 mm reinforced concrete with cooling pipes. In the layer of gravel will be hot pipes to prevent frost in the ground. The cooling and heating system is described in Section 3.3.2. The concrete floor should be cast without joints. It must be arranged so that there is a sliding layer between the insulation and concrete. The floor should not be connected to the building (floating floor) as movement in the building will give movement of the floor.

In building the tolerance requirements of the plan are vital, especially the pipes under the surface. Fixation of the cooling pipes to prevent them from floating up during casting is important. Liquid in the pipes during the pouring helps to keep the pipes in place.

Separate columns, beams and frames

The grid bearing in the rink has steel bars placed along the outside wall, c 7200 mm and a lattice of steel beams as the main carriers for the roof construction. As a basis for an eventual extension of the rink from 2 to 4 sheets, the columns in the exterior walls will be designed for additional loads they receive.

The building will be braced by steel crosses in the ceiling and walls.

Bearing floors and bearing interior walls.

Bearing floors and walls in the rest of the building are built with standard wooden joists and wooden walls.

Roof Structure

The roof structure will be made of light weighing elements hung between lattice beams

Fire protection

Steel structures in the outer wall should be encased while the exposed steel parts of the roof are fire-resistance painted to achieve a fire safety class corresponding EI 30. Rental areas will increase

the fire safety requirements and should be considered in each case. Technical rooms must be designed in fire-resistance class corresponding EI 60

Fire Techs consider a curling rink to be one fire-risk unit.

Acoustics

In a curling rink, acoustics are very important as communication between players is an important element in curling.

It is recommended that on the 'short' wall that is furthest from the public space there is sound absorption (hard surfaces must be avoided). The short wall closest to the public space must be of glass.

In the roof it is recommended to put sound dampening from hack to hogline at both ends of the rink. Between the two hoglines it is recommended to install sound reflective material. If there are fans and technical installations in the field of play there must be measures against noise and vibration.

It is generally recommended that a sound check is carried out to simulate how the sound will be perceived in a curling rink with different walls and building materials. An acoustic expert during the planning period is a good choice.

3.3.2 HVAC System

HVAC Systems for a curling rink involve:

- 31 Sanitation
- 32 Heating
- 35 Refrigeration
- 36 Air treatment
- 56 HVAC controls

The descriptions are based on a 4-sheet rink. For the other examples, the figures are scaled in relation to this.

Climate-wise, the rink is divided into two areas: the ice rink and the service areas. The quality of the ice is more important than the comfort of the curlers.

Good ice quality is achieved when there is a microscopic layer of melted water on the ice surface, as this provides the minimum friction, but too much water on the ice surface is undesirable.

31 Sanitation

The plan is to use conventional sanitary facilities with an electric water heater. Due to expected low consumption and potential legionella problems we do not recommend preheating water from the ice plant. Typically, a 300 litre, 2kW water heater tank would be used and could be located in the ceiling and linked to drains.

For high quality ice, water used must be purified, so a de-ionising or reverse osmosis system is required. Before the water enters the de-ionising filter it needs to be at a temperature of 40°C. It is recommended that a separate water heater be installed for this. This way, losses from hot water heaters can be avoided all winter. Approximately 2 m³ of water is needed for four sheets. If we have a temperature of 80°C in the heater, it requires 1000 litres mixed 50% via a direct-acting mixing valve. This need can be met by two water heaters of 600 litres and with 5 kW of power. A water to water heat exchanger can also be used to heat the flooding water. Purified water is very aggressive so stainless steel and/or plastic materials have to be used in contact with the water.

In addition, it is necessary to have a smaller separate system for water for "pebbling" the ice - for example, a separate 30 litre water heater in continuous operation. Here, too, a mixing valve or a thermostat should be used.

The drains need to be able to cope with melted ice at the end of the season.

32 Heating

The areas outside the ice rink need to be heated in the winter months. The Chilled Water unit produces some heat which would be appropriate to use for this purpose. It is "free" heat which would be "dumped" to the outside air if not used in this way.

The temperature from the refrigeration machinery for machines without climate polluting refrigerants is approximately 40°C. This is a relatively low temperature which can be difficult to exploit, but it can be used in floor heating systems and as pre-heating of ventilation air. Based on this, we recommend the installation of water-borne floor heating pipes in service areas.

With heat supply from the ice plant, there is a risk of having no heat if the ice plant is not running, so a standby system is required.

The recommended installed specific power is 50 W/m² for an area of 300 square metres and power for the entire floor heating system, based on these figures is 15 kW. It is recommended that floor heating be divided into regulatory zones so that the temperature in different zones can be controlled separately. For this, you can use a standardised system from a floor heating supplier. The thermal power need for ventilation of the service area is 11 kW, see Point 36

In addition to heating floors in the service areas, some heat under the ice insulation is needed. With 10 cm plate isolation, you only need 5 W / m² to avoid frost underneath the floor. The total need for this is about 5 kW. Floor heat under the ice is recommended from the return temperature pipes from the warm side of the refrigeration plants.

In the ice hall the climate in general and air temperature must be adapted to the level that provides the best ice quality.

There are no other heat sources out of the ice rink other than the ventilation system. To achieve an air temperature of 10°C needs approximately 10,000 cubic metres per hour of air, with a temperature of 28°C. Power needs to heat the air will be about 100 kW.

Total thermal power needs for heating and ventilation will be approximately 130 kW.

Running the refrigeration plants would, in principle, be enough to cover thermal power needs. However, the plants only run on full capacity at the beginning of the season. Otherwise, the plant

runs on around 40% of full capacity. We cannot achieve 100% coverage from ice plants and need to use other energy sources as well.

35 Refrigeration

The quality of the ice is the key element in a curling rink. In an ice-making plant there are 3 main elements - the refrigeration unit or refrigeration machine, pipes with cold media (a salt water (brine)/glycol mixture) to keep the ice cold, and finally the hot side (condenser side) where the energy collected from the ice is transported away - this is the surplus heat mentioned in Point 32.

The plant must use a medium which is environmentally friendly and does not produce greenhouse gas emissions. At the time of writing, the only medium in standard use is ammonia (NH₃). There has been a lot of research and development in this area, and it may be that ammonia is no longer recommended in future. A high specification unit is required.

A 4-sheet curling rink will need an ice surface of about 900 m².

Maximum needs for an ice pad is approx. 175 W/m² cooling effect which gives a total required cooling effect of about 160 kW. A typical unit which emits this cooling effect has an electrical power need of approximately 75 kW. It is important to locate refrigeration plants so that the temperatures from the warm side - 40°C - can be used for service area heating and preheating of ventilation air.

If the ice plant needs 160 kW and the rest of the rink needs 75 kW (a total of 235kW) this is sufficient to cover the power needs of the under floor heating and ventilation when the plant runs at full effect. However the plant will usually not be at full power and it is therefore necessary to use electricity for heating in order to cover the entire power requirement. The electric heat will also act as a backup, so that plants can operate even if the ice is not operational for any reason.

Coming out from the cold side of the refrigeration plant will be the pipes for the ice pad. These pipes should be placed across (perpendicular) to the length of the curling sheet to avoid freezing ridges along the sheets. To get to an even temperature on the surface we recommend that the pipes are covered with 2.5 to 4 cm of concrete and are placed at a distance of 8 cm between the centres of the pipes. The solution in the pipes should be a mixture of brine and glycol in proportions so that there is no risk of freezing. A blend of 30% glycol will counteract this. Ethanol is also widely used.

The temperature of the medium in pipes is initially -10°C, but this can be adapted from the temperature and medium that provides the best ice. This can vary from rink to the rink and must be experienced during operation of the facilities.

The higher the temperature, the lower the energy consumption will be. A typical temperature differential of the medium running in and out of the machine is 3°C but as low as possible is recommended.

As an alternative to using brine, glycol or ethanol, CO₂ can also be used as a secondary medium in pipes. Heat recording occurs through the evaporation of CO₂ and then avoids temperature variations in the pipe system.

Control of the refrigeration system can be done with probes in/under the ice, an IR probe or a sensor on the return brine. It should be added to all these possibilities so that the optimal form of regulation of the facilities can be applied.

Residual heat, not used in the heating system, should be dumped by a dry cooler placed outside.

To reduce the radiation loss from the ice, reflective material should be installed in the roof or under the ceiling. The surface of this material should be level to provide the most homogenous reflection.

The room for the cooling unit should be placed on the long side of the tracks. This should be a separate room dedicated to the cooling unit. Outside the room a space should be reserved for a dry cooler for dumping residual heat.

To achieve the most rational ice maintenance there should be a 'parking lot' for a power ice scraper ('Ice King') in the curling rink. The parking needs to be near the ice, but should not be an obstacle to players or for access. The area must have a plastic surface to avoid the ice scraper blade from corroding and melting the ice.

In addition, space needs to be set aside for a separate 'snow drain' for disposal of snow from the power ice scraper. The snow drain should be placed next to the ice scraper parking area. The snow drain should be shaped like a sink with a connection to a drainage system, so that the melted ice is disposed of in a sustainable way.

36 Air treatment

To meet regulations, a 4-sheet ice rink needs to have an air flow of approx. 5000 m³ / h, assuming a total floor space of 1050 m² and 40 people being present in the space. Since the rink should not have other heating arrangements other than the ventilation recommended, the air volume needs to be increased if the demand for heat increases. It is not rational to increase fresh air supply, but instead to use the re-circulating airflow of over 5000 m³/h. Necessary heating requirements for the unit is approx. 100kW (recycling factor of 0.7) With an air volume of approx. 10,000m³ and a incoming air temperature of 25-30°C favourable temperature conditions in the rink can be achieved with a minimal supply of electrical energy.

In an ice rink, the temperature will usually be low on the ice surface, while heat will rise up to the roof. The air from the air treatment plant should be supplied in such a way that it does not rise up under the roof. This is done by using symmetrical nozzles or adjustable horizontal/vertical vents. Air flow must be adapted to the distance from the outlet to the ice surface. For good ice the speed of the air at the ice level should not exceed 0.15 m/s but no air movement at all is of course better.

An example of incoming air in a 4-sheet rink will be to have two main air conditioning pipes along the roof between the sheets 1-2 and 3-4. The angle of the vents must be aimed at the centre of the room. The number, size and distance must be adjusted for the airflow and reach.

It is recommended to place an extraction unit centrally in the roof.

At the start of season, when new ice is added, there will be a need for dehumidification. There should therefore be a cooling coil for this purpose in the ventilation unit. The refrigeration system would produce the cooling needed for this purpose.

The unit should have a rotary exchanger so that energy demand for heating is minimized. It should come with affordable energy-driven fans with a frequency converter.

Air flow can be reduced to conserve energy when the plant is not in use. When the plant is in operation there must be constant air volume. The balance in the system would be compromised

by reduced airflow. Inside temperature can also be reduced when the plant is not in use. The operating status can be defined via the timer, motion detector or a combination of both.

There should be a separate room dedicated to air treatment and heating. The room should be located between the rooms for refrigeration generators and service zone.

Service areas can, for example, use a standalone unit as this requires less space for the technical room. On the basis of expected use of areas should be taken out with approx. $10 \text{ m}^3 / \text{h} \cdot \text{m}^2$ It is recommended rotating the heat exchanger and battery with energy from ice production. A 4 sheet rink will need $3,000 \text{ m}^3 / \text{h}$ and the heat demand is estimated at 11 kW (recovery rate 0.7). The unit should be installed with CO₂ and temperature sensors for command-controlled air flow.

56 HVAC Controls

The number of panels should be adapted to the geography and location of the different systems. But basically, one should have as few switchboards as possible. Energy consuming equipment should obtain power directly from the power switchboard. The system can be tied into the central power plant if desired.

General technical requirements for DDC (Direct Digital Control) facilities are:

- The individual technical systems should function completely independently of any power failure at the central plant and without loss of key information.
- After a voltage loss/power failure the plant should start up automatically and control itself and all associated equipment. The plant should be able to start up automatically with preset information.
- Sub-centres: Decentralized programmable device for controlling, regulating, collection and processing of process information in technical installations will be able to operate autonomously and independently (Autonomous). The centre will be able to perform all climate regulation functions and logical controls for the described system.
- All communication between man and machine will be carried out within the building's frame of reference with clear instructions and function keys in Norwegian.
- The parameters are all defined and feeding from one point. It includes all programming/generation, design, supply and commissioning for regulation, control and surveillance. Alignments of all user-defined set points, control curves, start/stop times shall be adjusted from the centre.
- The Operator Panel is linked to the sub-centres and can obtain all the information and adjust all programming parameters.
- The plant will be equipped with a real-time clock and year clock.
- There are general requirements that only open standards and interfaces should be used for communication.
- The sub-centres will have 2-way communication with each other.
- Communication protocols should preferably be in clear, well-known and available standards.

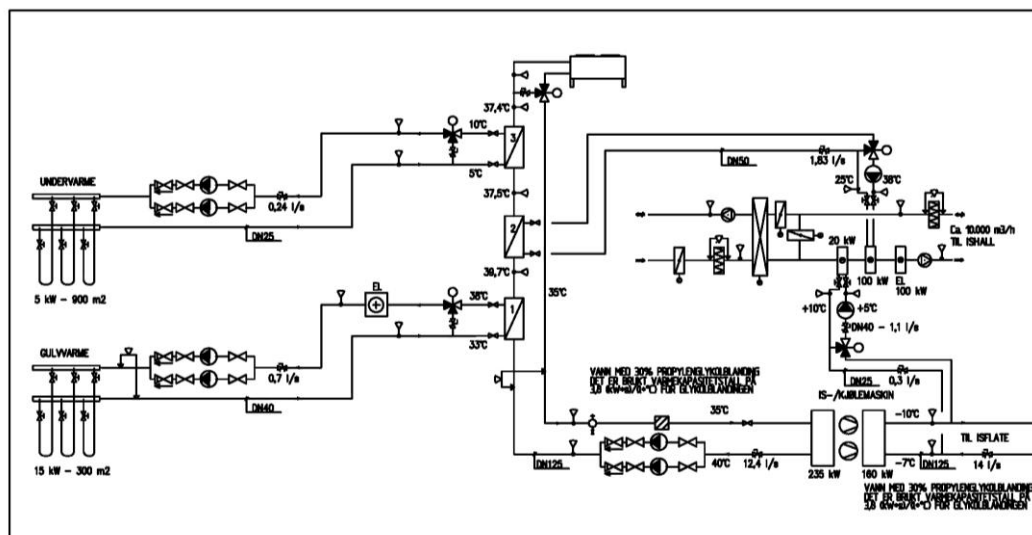

Figure 3.5: System diagram for refrigeration machine utilization in heating.

3.3.3 Electrical

Electro-technical facilities for a curling rink will be:

- 40 Electrical - General
- 41 Basic Installation of Electric Power
- 43 Low voltage supply
- 44 Lighting
- 45 Electric heating
- 52 Integrated communications
- 54 Alarms and Signals
- 55 Audio and Video
- 62 Elevator

Assessments the electro-technical requirements for a curling rink must be taken with respect to the lighting of the ice rink. 'Television Light' generally means higher standards than normal lighting. In this report, it is assumed that a curling rink has 'normal' lighting.

40 Electrical - General

In the rink, outlets are needed for computers, ice scraper, etc. For the other rooms, sockets are required for vacuuming, cleaning and cooking.

41 Basic Installation of Electric Power

Basic installations are cable ladders, rails and fittings to earth the power in the building.

43 Low voltage supply

This point includes electric power supply to the building and the building's main switchboard with the distributions of electric power. For the cost estimate, an input cable is taken from the Electricity supply company. A main switchboard distributes power to all of the outputs in the building including the HVAC Controls. It is calculated under a distribution of consumption rates.

44 Lighting

In this report, it is assumed that a curling rink has standard lighting. 'Television lighting' implies generally higher standards than the standard lighting.

Norwegian lighting standards are considered inadequate for a curling rink. These requirements dictate that the lighting in the house of a curling sheet should 300 lux and on the walkway 200 lux. At the same time the smoothness should be more than 0.7.

Curling-related requirements recommend an average of 350 lux for the full sheet

For lighting in other rooms we used recommendations from "Selskapet for lyskultur" (Norwegian publication).

45 Electric heating

Heating of the building should be done with water-borne heat to take advantage of the surplus heat from refrigeration plants. Electric heating should be limited as much as possible.

52 Integrated communications

A connection for transmitting data via PC to the internet and for the transmission of alarms is required. This should be by mobile telephone rather than land line.

54 Alarms and Signals

Consideration should be given to equipping doors and any doors to changing rooms with card readers. The elevator must have an alarm connection.

55 Audio and Video

For each sheet, cameras should be placed in the roof above the house away from the viewing lounge. They should be linked to TV screens in the viewing lounge to make the activity on the ice more spectator-friendly.



Figure 3.6: Example of a TV monitor and overhead camera in Snarøya rink.

An alternative to the cameras and TV monitors is a tilted mirror between the roof and the wall of the house away from the viewing lounge. The disadvantage is that the mirror creates shadow effects when players are moving on the ice.

In curling rinks electronic scoreboards are increasingly common. Such boards can be connected directly to the internet and give 'live results' of competitions.

There should be a TV antenna in the viewing lounge.

62 Elevator

If the curling rink built over several floors, there must be a lift for disabled curlers and spectators. The lift must have a secure cable for power supply and an alarm with voice connection to a security company.

4. Economics

For any new curling facility a business plan with an economic evaluation is essential. A detailed assessment of the costs involved in both the establishment and operation of the rink is required. It is important to plan how the facility will be financed and also highlight the income opportunities the rink will have. These factors are discussed in more detail in this chapter.

4.1 Investment costs

Investment costs for a curling rink can be divided into: 1 - construction costs and 2 – ‘curling-specific’ costs.

4.1.1 Construction costs

Costing for investment in facilities for the three Concept Rink solutions is based on the principles described in the preceding chapter, and unit prices. The calculations are carried out according to the NS 3453 (Norwegian Standard Specification of construction project costs, 1st edition January 1987). We emphasize that the cost estimates are realistic. They reflect the current situation in the Norwegian construction market (February 2007).

Assumptions

In addition, the following assumptions have been made in the cost calculations:

1. 10% has been allocated on point 1-9: margins and reserves.
2. 10% of construction cost is included for design.
3. 3% of the construction cost is included for construction management, sub costs and fees, etc.
4. Special taxes - VAT (sales tax) - and costs for land are excluded.
5. Costs for outdoor work are excluded.
6. The calculation for the 2+2 sheet rink is provided that it is built simultaneously.
7. A lift is included in the costs at 500,000 NOK.
8. Floor heating is in all service areas (300 m² for 4-sheets and 200 m² for 2-sheets).
9. The total ice surface (areas with cooling pipes) for 4 sheets (2+2) is 920 m² (460 m² for 2-sheets).
10. Water-borne heat is under the ice surface (estimated under Point 32 Heating).
11. A de-ionizing plant is included (estimated under Point 31 Sanitary Facilities).
12. For 2+2 sheet rink, the cost of partitioning the ice into different zones is included. Thus enabling multi-use of the ice.

Total investment costs

The total investment costs for the various Concept Rink solutions are shown in Table 4.1, while the construction costs broken down into the main elements of the most central areas are shown in Table 4.2.

Cost calculation		2 sheet Rink	2+2 sheet Rink	4 sheet Rink
Description		NOK	NOK	NOK
0	MARGIN & RESERVE	1 114 713	1 763 443	1 739 639
1	COMMON COSTS	896 793	1 418 699	1 399 549
2	BUILDING	5 080 000	8 130 000	8 380 000
3	HVAC SYSTEM	2 700 000	4 654 000	4 212 500
4	ELECTRICAL	578 978	744 040	744 040
5	TELECOMS & AUTOMATION	108 950	158 950	158 950
6	OTHER INSTALATIONS (elevator)	500 000	500 000	500 000
0-6	BUILDING COST	10 979 434	17 369 132	17 134 678
7	OUTDOOR WORK COSTS	0	0	0
0-7	CONTRACTOR COSTS	10 979 434	17 369 132	17 134 678
8	GENERAL EXPENSES	1 282 414	2 028 740	2 001 355
0-8	CONSTRUCTION COST	12 261 848	19 397 871	19 136 033
9	SPECIAL EXPENSES	0	0	0
0-9	PROJECT COST - exclu.VAT (rounded up)	12 300 000	19 400 000	19 150 000

Table 4.1: Construction costs for different solutions for Concept Curling Rinks).

A 2-sheet rink is estimated to cost about 12.3 million NOK while Concept Rink solutions with 2+2 and 4 sheets are estimated at just over 19 million NOK. This means that the cost of establishing a 4-sheet curling rink compared with a 2-sheet rink is only approximately 1.5.

The major cost items are generally related to the building work itself and the HVAC system. The choice of heating system for a curling rink should be considered in relation with life cycle costs and not just investment costs.

In this report, it is recommended that the pipes for cooling the floor be laid across/perpendicular the length of a curling rink. Transverse pipes require the same length of pipe, but a greater number of connection points.

COST CALCULATION		2 Sheet Rink	2+2 Sheet	4 Sheet Rink
#	Description	NOK	NOK	NOK
0	MARGIN & RESERVE	1 114 713	1 763 443	1 739 639
1	COMMON COSTS	896 793	1 418 699	1 399 549
10		0	0	0
11	Rigging	448 396	709 350	699 775
12	Operation of the construction site	448 396	709 350	699 775
13	Construction Administration	0	0	0
14	Other common costs	0	0	0
15		0	0	0
16		0	0	0
17		0	0	0
18	Building-related work	0	0	0
19		0	0	0
2	BUILDING	5 080 000	8 130 000	8 380 000
20	Building general			
21	Base and foundations	970 000	1 350 000	1 250 000
22	Primary building elements	3 010 000	5 080 000	5 430 000
23	Secondary building elements outside	100 000	100 000	100 000
24	Secondary building elements inside	400 000	800 000	800 000
25	Surfaces	0	0	0
26	Technical building components	100 000	100 000	100 000
27	Fixed inventory	500 000	700 000	700 000
28	Prefabricated Rooms	0	0	0
29	Other construction parts	0	0	0
3	HVAC SYSTEM	2 700 000	4 654 000	4 212 500
30	HVAC installations, generally	0	0	0
31	Sanitation	300 000	500 000	495 000
32	Heating	400 000	620 000	585 500
33	Fire fighting	0	0	0
34	Gas and Compressed Air	0	0	0
35	Refrigeration	1 200 000	2 200 000	1 868 000
36	Air Treatment	450 000	784 000	784 000
37	Air Conditioning	0	0	0
38	Water treatment	0	0	0
39	Other HVAC installations	350 000	550 000	480 000
4	ELECTRICAL	578 978	744 040	744 040
40	Electrical - general	241 930	300 200	300 200
41	Basic Installation of Electric Power	49 000	88 000	88 000
42	High voltage supply	0	0	0
43	Low voltage supply	180 000	235 000	235 000
44	Lighting	103 648	116 440	116 440
45	Electric heating	4 400	4 400	4 400
46	Reserve power	0	0	0
47		0	0	0
48		0	0	0
49	Other electrical installations	0	0	0

5	TELECOMS & AUTOMATION	108 950	158 950	158 950
50	Telecoms & automation - general	0	0	0
51	Basic Installation of telecoms & automation	0	0	0
52	Integrated communications	3 450	3 450	3
53	Telephony and paging		0	0
54	Alarms and Signals	53 000	53 000	53 000
55	Audio and Video	52 500	102 500	102 500
56	HVAC Controls	0	0	0
57	Instrumentation	0	0	0
58		0	0	0
59	Other installations for telecommunications	0	0	0
6	OTHER INSTALATIONS (elevator)	500 000	500 000	500 000
0-6	BUILDING COST	10 979 434	17 369 132	17 134 678
7	OUTDOOR WORK COSTS	0	0	0
0-7	CONTRACTOR COSTS	10 979 434	17 369 132	17 134 678
8	GENERAL EXPENSES	1 282 414	2 028 740	2 001 355
0-8	CONSTRUCTION COST	12 261 848	19 397 871	19 136 033
9	SPECIAL EXPENSES	0	0	0
0-9	PROJECT COST - exclu. VAT (rounded up)	12 300 000	19 400 000	19 150 000

Table 4.2: Construction costs for different solutions for Concept Curling Rinks (specified).

In recent years, curling in Norway has seen a marked upturn and has significantly increased interest. For Snarøya Rink this has resulted in a 'positive development' which maintains a balance between sporting considerations (with respect to recruitment and active players) and commercial interests. The expansion of Snarøya curling rink from 4 to 6 sheets means that the rink will be able to meet demand from schools, curling clubs, businesses... better. The rink will also be upgraded. The cost for this upgrade is calculated to be about 10 million NOK (incl. VAT) (see Table 4.5).

4.1.2 Activity-specific costs

Once you have built a curling rink, there is need for activity-specific procurement. The most important is the acquisition of curling stones. Most curling stones are made of special granite from a small island off Scotland called Ailsa Craig (see Figure 4.1). In addition, equipment is needed to make sheets and for ice maintenance



Figure 4.1 Ailsa Craig

In order to play curling you need brooms and special shoes. Many rinks have such equipment for loan or rental. Such equipment is not included in the cost estimate for 'curling-specific' costs.

Table 4.3 shows an estimate of the 'curling-specific' investments in equipment that are necessary for a 2-sheet curling rink, while Table 4.4 shows the equivalent for a 4-sheet rink (including 2+2 rinks).

Equipment - 2 sheets	Total (NOK)	Total (%)
Curling Stones (32)	115 000	52%
"Stone bumper"	2 000	1 %
Brand Inserts (mark-up)	8 000	4%
Hacks (8)	7 000	3 %
Ice scraper ("Ice King")	53 000	24%
Ice scraper (manual)	1 000	0%
Ice mop	1 000	0%
Ice thermometer	6 000	3 %
Pebble can	2 000	1 %
Pebble heads	1 000	0%
Measuring instruments	1 000	0%
Other measuring instruments	3 000	1 %
Miscellaneous (10%)	20 000	9 %
Equipment 2 sheets	220 000	100 %

Table 4.3: Curling-specific investment for a 2-sheet curling rink (NOK).

Equipment - 4 sheets (and 2+2)	Total (NOK)	Total (%)
Curling Stones (64)	230 000	62 %
"Stone bumper"	4 000	1 %
Brand Insert (mark-up)	16 000	4%
Hacks (16)	14 000	4%
Ice scraper ("Ice King")	53 000	14 %
Ice scraper (manual)	2 000	1 %
Ice mop	1 000	0%
Ice thermometer	12 000	3 %
Pebble cans	2 000	1 %
Pebble heads	1 000	0%
Measuring instruments	1 000	0%
Other measuring instruments	3 000	1 %
Miscellaneous (10%)	34 000	9 %
Equipment 4 sheets	373 000	100%

Table 4.4: Curling-specific investment for 2+2 and 4-sheet curling rinks (NOK).

Costs are based on unit prices for equipment from the equipment supplier are excluding VAT. Prices are based on a conversion rate for NOK / CAD at 5.70 (2007).

The tables show that the largest investments are related to purchase of stones and the special ice scraping machine ("Ice King").

In addition, some costs are fixed, regardless of the number of sheets. In general investment costs decrease with more sheets.

Concept Rinks with 2 +2 sheets are intended specifically for cooperation with other ice sports (skating, ice hockey, figure skating, etc.). This solution means more ice preparation and more maintenance.

4.2 Operating Costs

Running costs

The cost of operating a curling rink will depend on many factors. In a broad sense we may include both building-related operating costs (including electricity, water, sewage, etc.) and personnel-related operating costs (booking service, ice maintenance, janitorial service, etc.).

These Concept Curling Rink solutions are based on an expected lifetime of 50 years for the building and 20 years for the technical installations. Expected lifetime is dependent on proper operation and maintenance.

Personnel-related expenses are not taken into account in this report. Generally, these costs will depend on many elements, such as the chosen operating model and localization in relation to other sports (cooperation/co-location).

The biggest operational - and the most important operating cost item by a curling facility - is energy. This is affected by the volume of the building and special requirements for ice quality and environment (temperature, humidity, air circulation, water quality, etc.).

Energy consumption

On this basis, the annual energy consumption for a 4-sheet curling rink is evaluated and calculated below. The basis for the calculations is a daily operation time of 14 hours (from 08-22) and an annual operating period of 300 days (closed in summer).

A distinction is made between the following forms of energy:

- Thermal energy
- Electrical energy

Thermal energy

In order to heat the *ventilation air* for the ice rink and service area to the desired temperature, it is estimated an energy consumption of 285,000 kWh / year is required. Using the air in the ice rink, this could be reduced somewhat.

Similarly, the energy for under floor heating in the service area is estimated at 40,000 kWh / year.

We can assume that as long as there is ice there will be a need for heating underneath the ice floor in order to avoid frost heaving. If we assume an average power of 3 W / m², the energy consumption for this would be 10,000 kWh / year but it could be 0kWh if the insulation is thick enough.

The norm for sports buildings for hot water is 50 kWh / m² per year, (estimated consumption for a sports building). In a curling rink, however, there will normally be very limited showering. We

assume, therefore, that water demand will be about half, around 25,000 kWh / year. This is basically covered by water heaters, but preheating of hot water from the refrigeration system can be considered.

For the best quality ice, the water needs to be maintained at a temperature of 40°C. The water must be heated. The amount of water that needs to be heated up is 2,5 m³ each time. Since this is only used a few times during the year, energy demand will be only a few hundred kWh (about 70 kWh per hour).

The total thermal heat demand under these conditions will be approx. 360,000 kWh / year. Some of this will be covered by electricity (hot water and for heating of ventilation air).

However, part of the thermal heat requirements can be *recovered from the refrigeration plants*. We estimate that the average effect of heat from the refrigeration plants will be 40% of full power. 300 days / year x 14 hours / day x 0.4 x 235 kW = 394,800 kWh / year. This, in theory, is more than enough to cover the entire heating requirement but one should still count on a certain use of electricity for heating. There will also be a need for additional heating of ventilation air to heat the ice rink. **(NB: WCF experience has shown that ALL heating requirements can be produced from the refrigeration plants)**

Electrical energy

The energy consumption for lighting accounts for approx. 25,000 kWh / year.

The energy consumption of pumps for refrigeration will be low relative to total consumption, and is therefore is not counted as a separate item. **(WCF experience approx. 60 000 kWh per 300 days)**

Fan power for the ice rink is 7 kW x 4200 hours / year = 29,400 kWh / year while the fan effect for the unit to a service area equivalent to 2.5 kW x 4200 hours / year = 10,500 kWh / year

For ice production we have estimated an average of 40% of full capacity through the year. Maximum power requirements for ice machines are 75 kW. Total power consumption is then 126,000 kWh / year.

On this basis, the total power consumption for a 4-sheet curling rink is up to 200,000 kWh / year.

Total energy consumption and costs

Taken together, this means that we come up with energy requirement of approx. kWh / year. This corresponds to approx. 415 kWh / m² per year, which seems very high. Of this, up to 300,000 kWh can be covered through recovered heat from the refrigeration plants. Then the numbers are better: 260,000 kWh / year or 193 kWh / m² per year. Here we have provided for a long operating life of 14 hours each day, all week. A shorter operating time will reduce energy consumption somewhat.

If we assume an electricity price of 0,70 NOK / kWh, the annual energy cost will be 182,000 NOK. Savings as a result of recovering heat from refrigeration plants amount to the equivalent of 210,000 NOK per year

4.3 Financing

Financing Solutions

The specifics of how the establishment of curling rinks will be financed are beyond the framework for this project. But generally, current financing solutions for construction and operation of a curling rink are divided into the following categories:

- Public funding (lottery, municipal funds, support from NCF / WCF, etc.)
- Club financing (equity, bank loans, membership fees, etc.)
- Private financing (investors)

The existing curling rinks in Norway have been mainly financed by public (municipal) funds in combination with club funding. Norwegian Culture Ministry (KKD) funds can be in the form of a lottery grant in support for sports of up to 50% of the total investment cost. It also is also possible to get support from the World Curling Federation (WCF) www.worldcurling.org both financially and practically in terms of procurement of equipment (stones). Such support will, in this case, be channelled through the NCF. The Curling rink in Halden, received financial support.

The budget and financing plan for the expansion of Snarøya Rink from 4 to 6 sheets is shown in Table 4.5. It stated in part that the funding of this facility is divided roughly 50/50 between the public and club (in this case, an operating company).

Financing	Budget (NOK)	Budget (%)
Bærum Municipality	1 700 000	17 %
Lottery funds	3 000 000	29 %
Bank loan	4 000 000	39 %
VAT	200 000	2 %
Equity inclusive voluntary work	1 300 000	13 %
Total	10 200 000	100 %

Table 4.5: Financing Plan for expansion of Snarøya ice rink from 4 to 6 sheets (2006)).

Operating Models

Financing Solutions for a curling rink should be considered in the context of the choice of operational model. Recent operational models for a curling rink have primarily been:

- Club (or more)
- Operating Company (AS or equivalent)

The Curling rinks of Bygdøy and Oppdal are owned and operated by the local curling clubs, while the management and use of Snarøya rink is organized by an operating company (A/S Curlingbaner). This company is owned by three local curling clubs (49%) and Norway's Curling Association (51%). A/S Curlingbaner has three part-time positions, of which one person is responsible for administration, a single instructor and one person who takes care of ice maintenance and cleaning. ,

In golf there are also several instances where an established independent operating company owns and operates the courses. The clubs and their members are thus buying services (playing opportunities) from the operating company. The benefit of such a solution is that the financial risk is transferred from the club to the operating company. This may be beneficial in relation to financial institutions (banks, etc.). Additionally, it leads to a clarification of the distinction between users of the facility, and those who run it (i.e. the owners).

Revenues

Willingness to pay for curling can be said to be lower than in some other sports, for example golf. According to Norwegian Golf Association, the average amount of money spent to play golf at a club is about 5000 NOK per year. The curling club for a year is up to 2000 NOK. Normally children and youths pay half price. Although Canada is a curling country, in general there is more willingness to pay for golf than to a pay for curling.

NCFs current membership (approximately 3000) indicates that the Norwegian curling today has a limited potential for member funding. If it is assumed that an average curler spends 1000 NOKs to play this corresponds to 3 million in annual income. If a curling rink is built in a place where a club has 500 members, it means 500,000 NOKs in annual revenue. This indicates that member fees alone could cover the interest on a loan of 10 million NOK.

Commercial revenue

Sheet rental to business and industry will be an important source of income for a curling rink. Snarøya rink does a "prime time" fee at 2000 NOK to rent one sheet with an instructor for 2 hours. On an annual basis the curling rink in Oppdal has commercial revenues of about 7-800,000 NOK.

5 Solutions for co-location

This report is focused on curling rinks as independent units (i.e. dedicated curling). Co-location of curling rinks with other sports will often be beneficial. This will create greater sports diversity and provide a richer sporting environment and have positive operational impact.

Co-location with other sports

For a curling rink co-location might be possible in relation to the following types of facilities:

- Indoor ice rink
- Multipurpose Sports Hall (for handball, basketball, etc.)
- Swimming pool / water park
- Artificial grass
- Skating Rink (gravel pitch in the summer)
- Tennis courts

Co-location with an indoor ice rink saves money because of the common infrastructure for building and technical installations. In this report it emerged that this is the biggest cost drivers in the construction of a curling rink. Experiences from Halden and Bergen suggest that there are significant savings in co-location of indoor skating rinks and curling facilities.

Furthermore, the co-location of a curling rink with a swimming pool, artificial grass or other facilities with large energy needs gives good energy savings.

Co-location with a golf course?

Another example of co-location is to link a curling rink with a golf course. The two sports complement each other seasonally - golf in the summer and curling in winter. This gives a broader base for year-round operation.

In addition, there are many similarities between the two sports. In Canada there are several examples of co-location of a curling rink and golf course at the so-called "Country Clubs" (an example is Donaldo Club in Toronto).

APPENDICES

- 1. Concept Curling Rink 2 sheets**
- 2. Concept Curling Rink 2+2 sheets**
- 3. Concept Curling Rink 4 (6) sheets**
- 4. Snarøya Curling Rink**
- 5. Oppdal Curling Rink**
- 6. Jar Curling Rink**
- 7. Tårnby Curling Rink (Denmark)**
- 8. Example - 6 sheet Rink (Canada)**

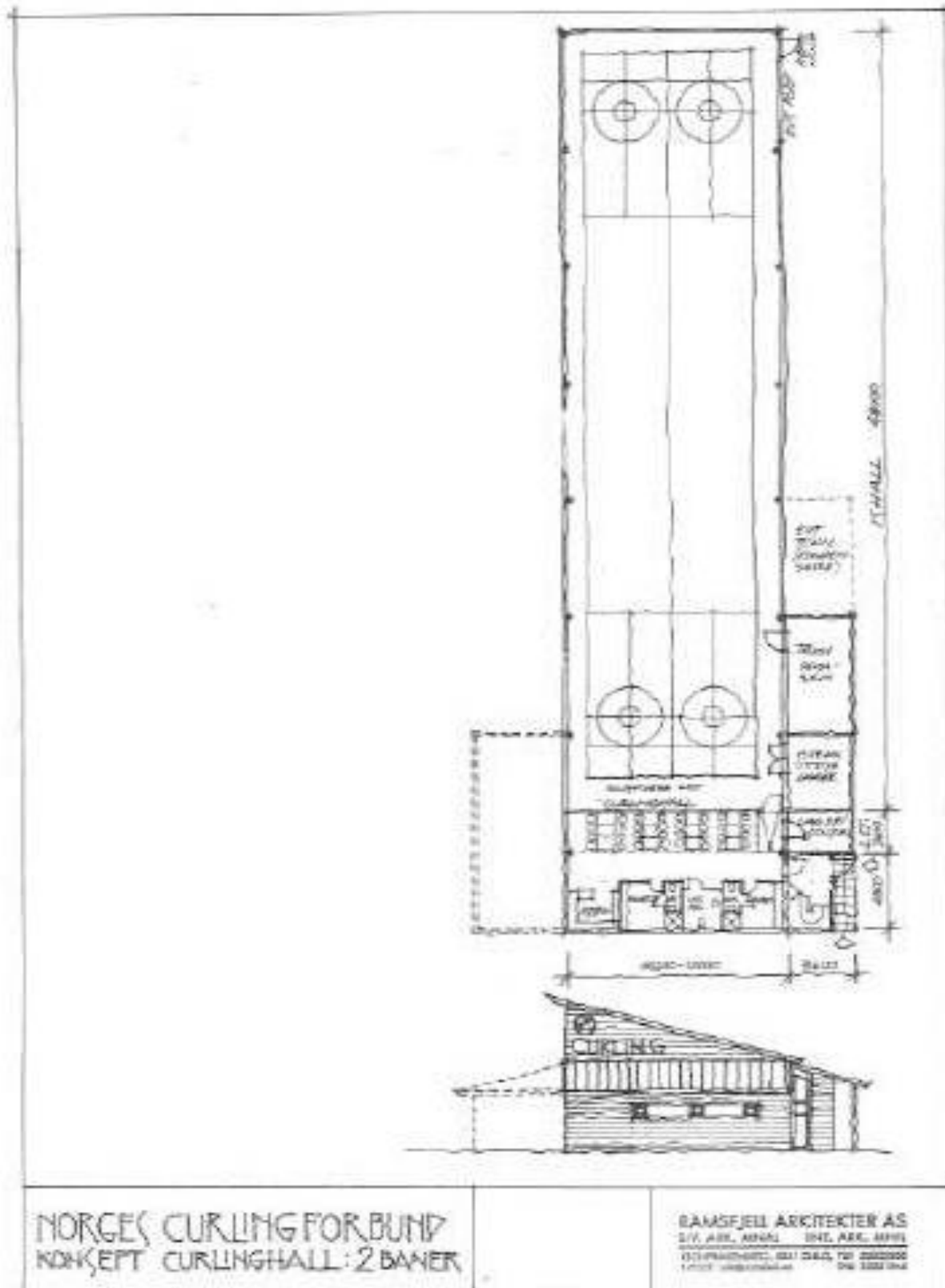

NORGES CURLINGFORBUND
 KONSEPT CURLINGHALL: 2 BANER

BÅMSFJELL ARKITEKTER AS
 SIV. ARK. ANNA LIND, ARK. BIRGITTE
 ESTERHAGEN, SIV. ARK. TOR
 19707

1. Concept Curling Rink - 2 sheets

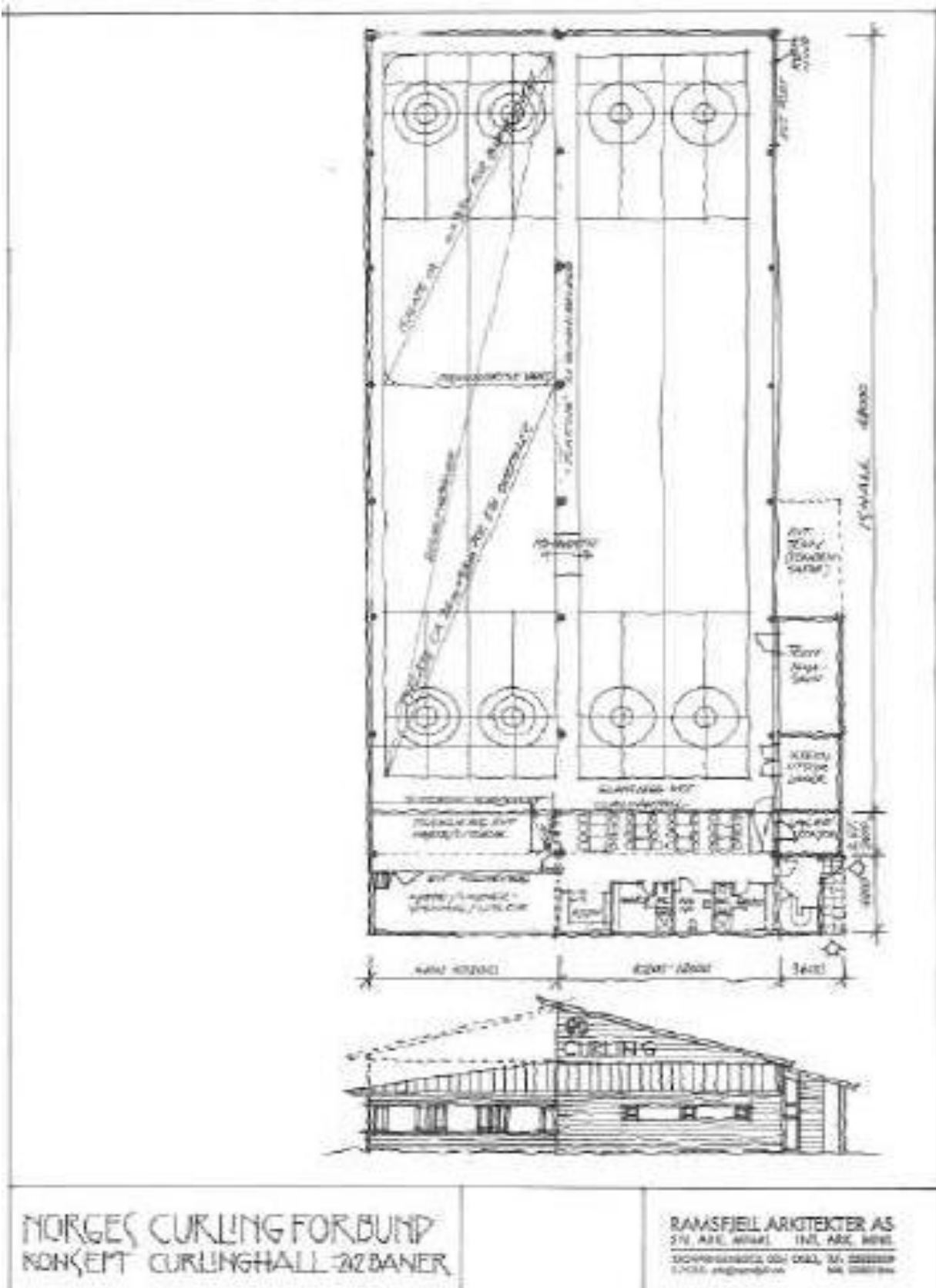

2. Concept Curling Rink - 2+2 sheets

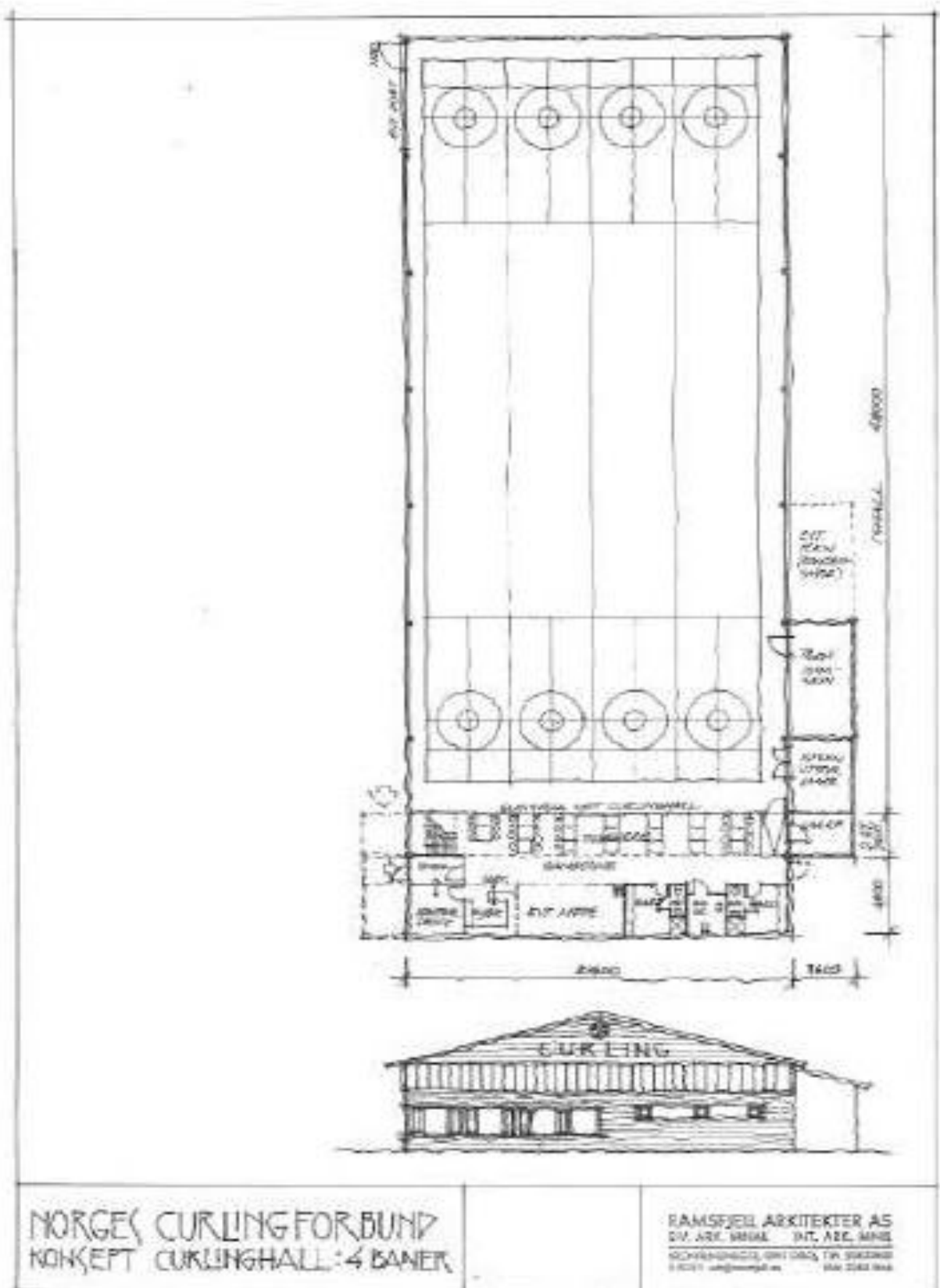

NORGE'S CURLINGFORBUND
 KONSEPT CURLINGHALL : 4 BANER

RAMSFJELL ARKITEKTER AS
 DIV. ARK. MNMIL INT. ARK. MNMIL
 SCHREIBERES, ØSTING, TR. ØSTING
 04021 ram@ramsfjell.no 040 228 1866

3. Concept Curling Rink 4 (6) sheets

4. Snarøya Curling Rink

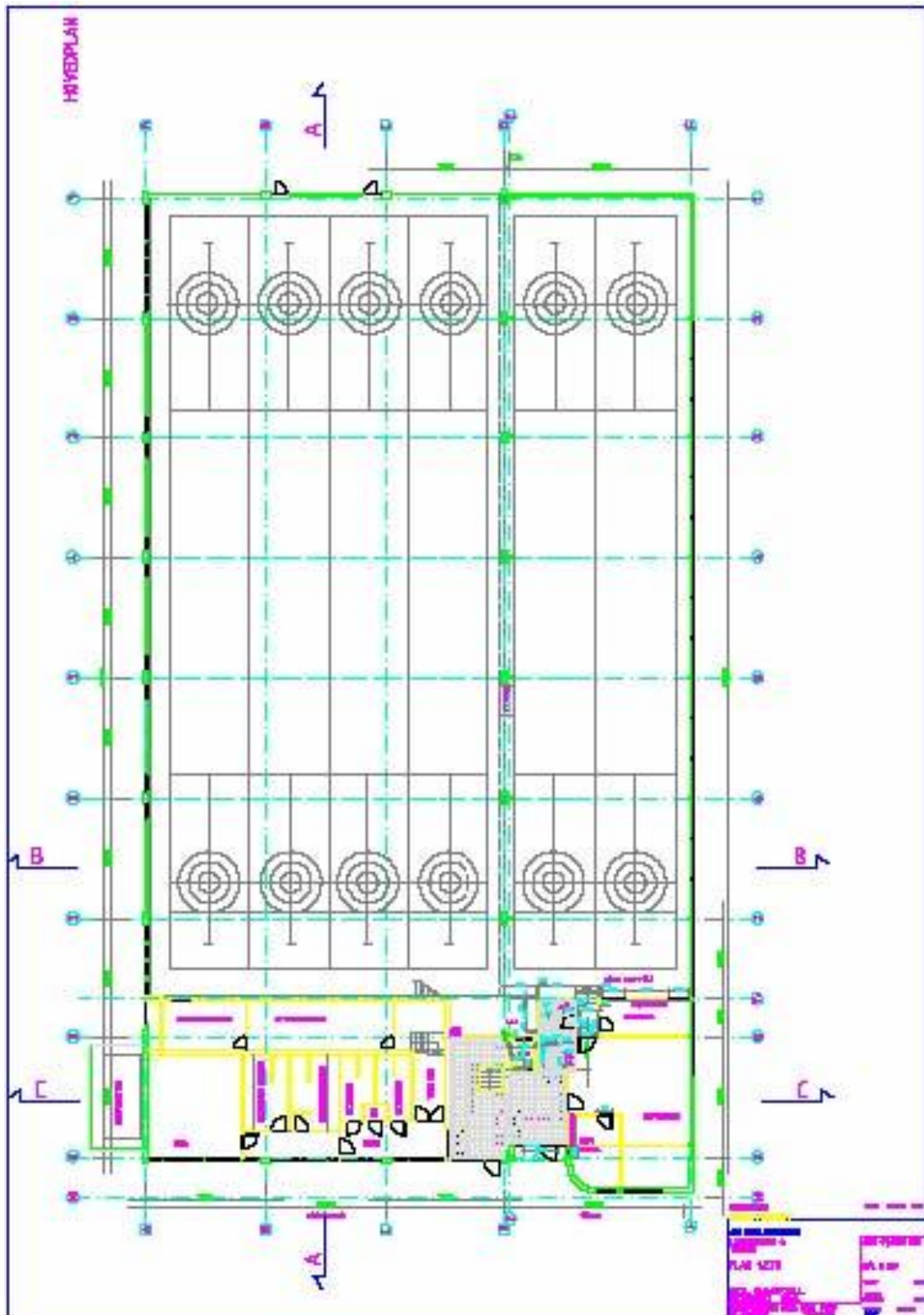

Plan - ground level

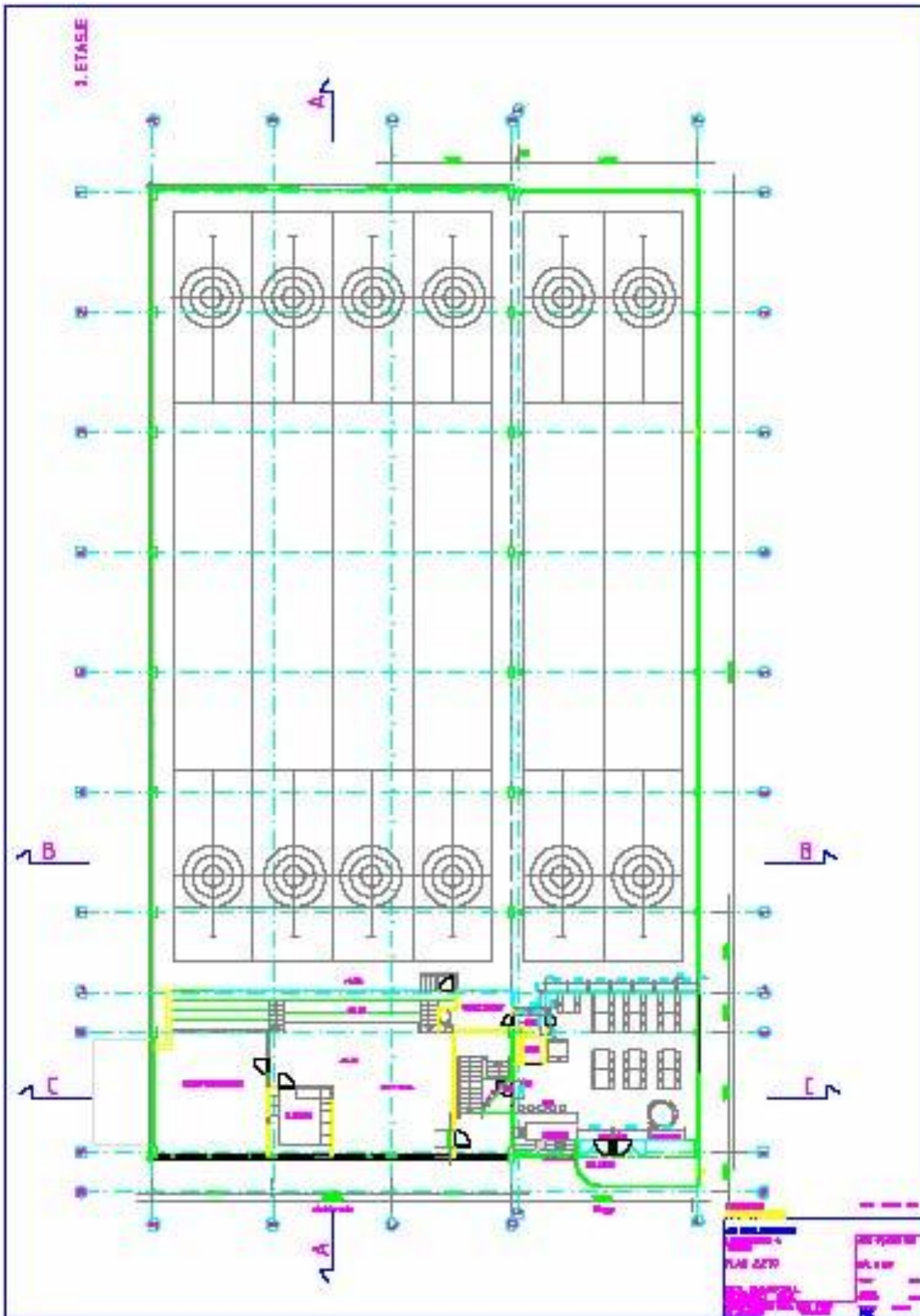

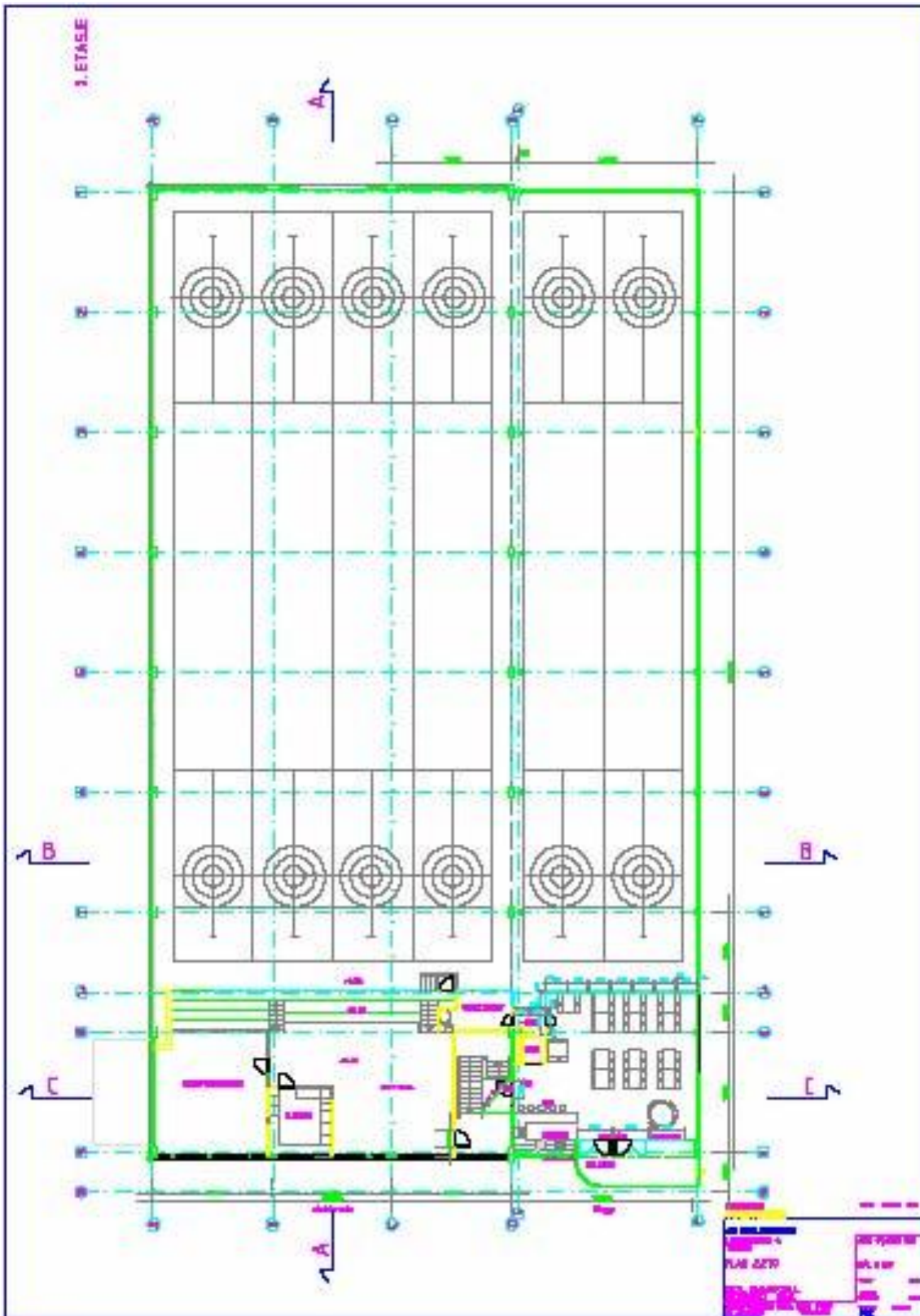

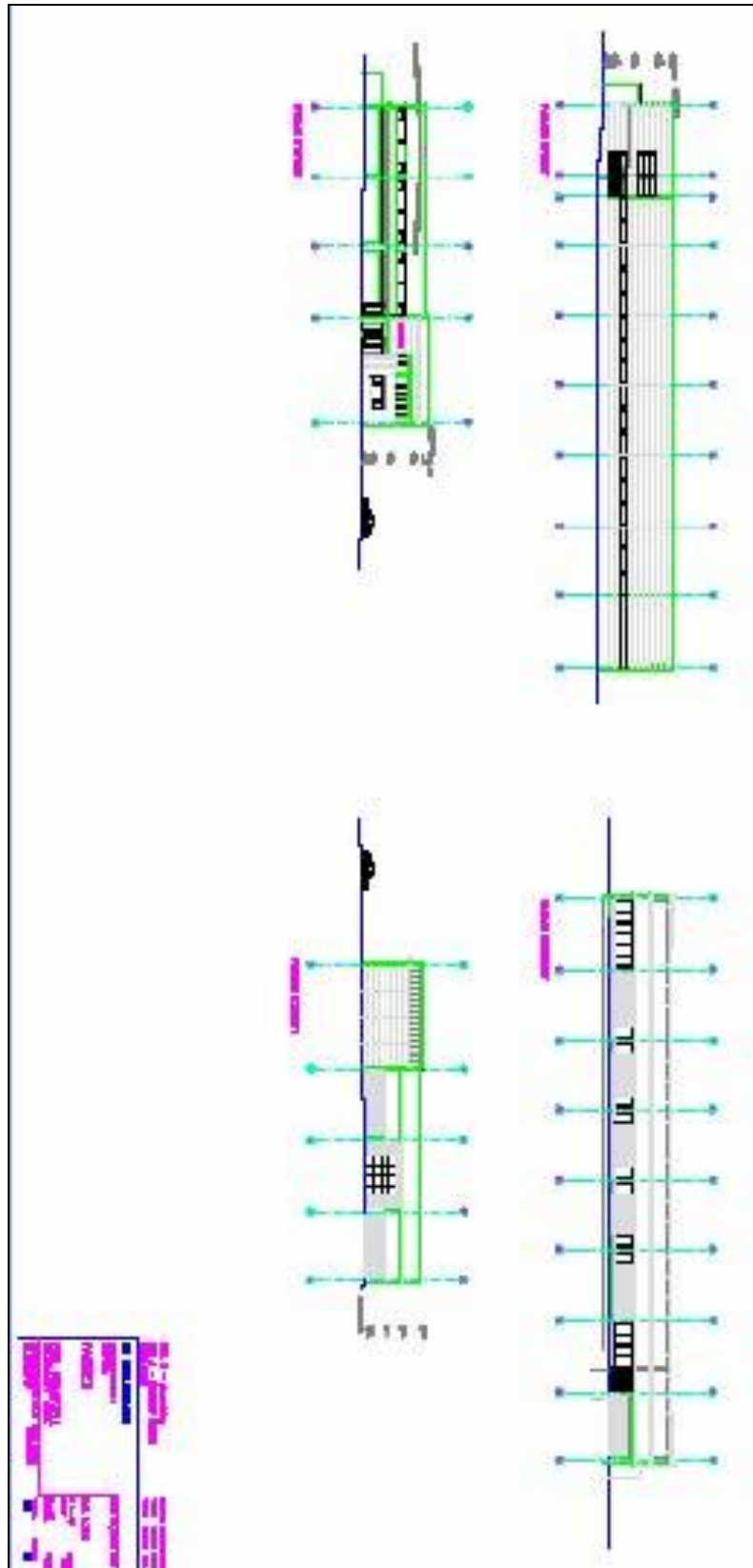

Exterior 1

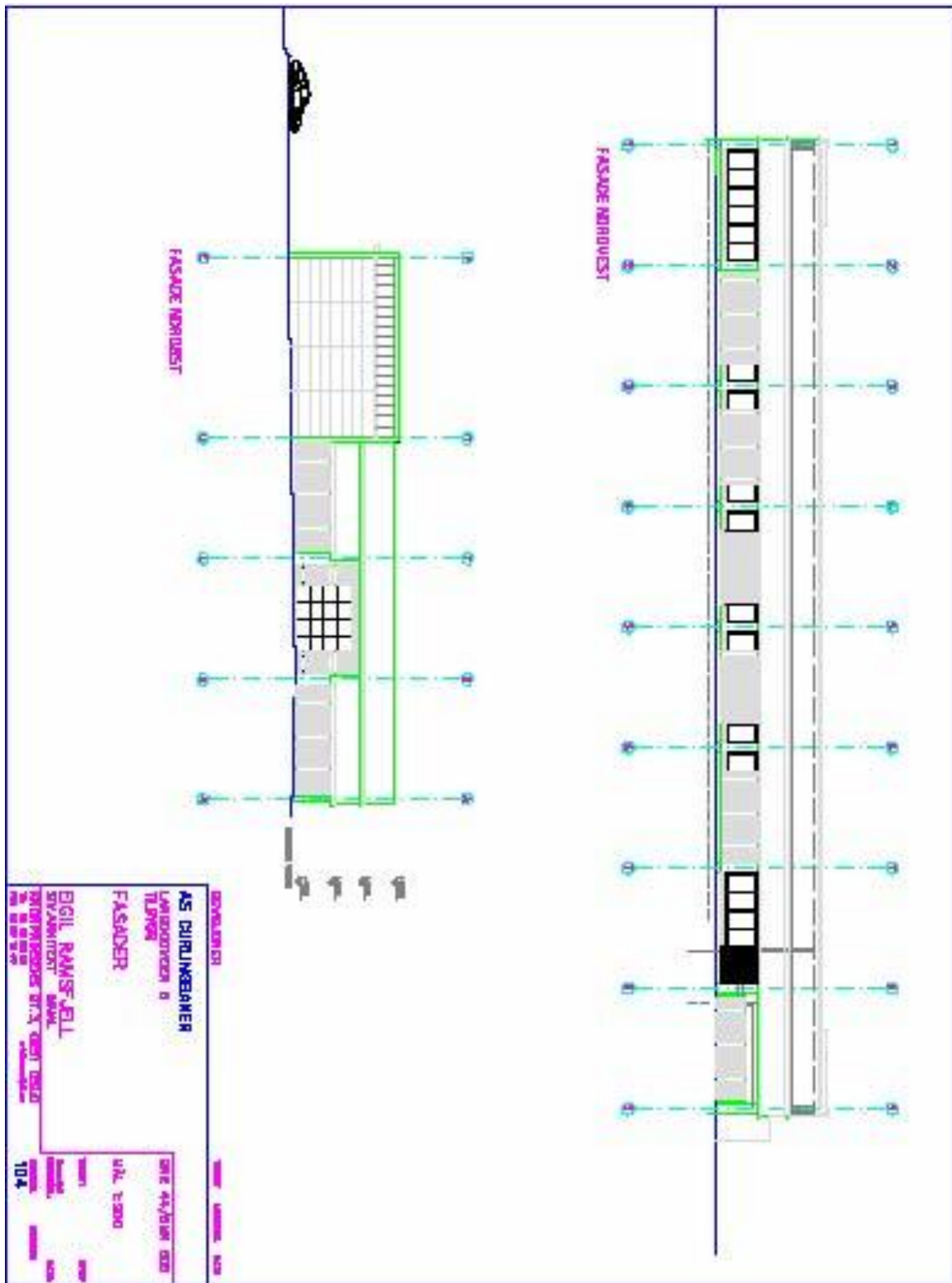

Exterior 2

5. Oppdal Curling Rink

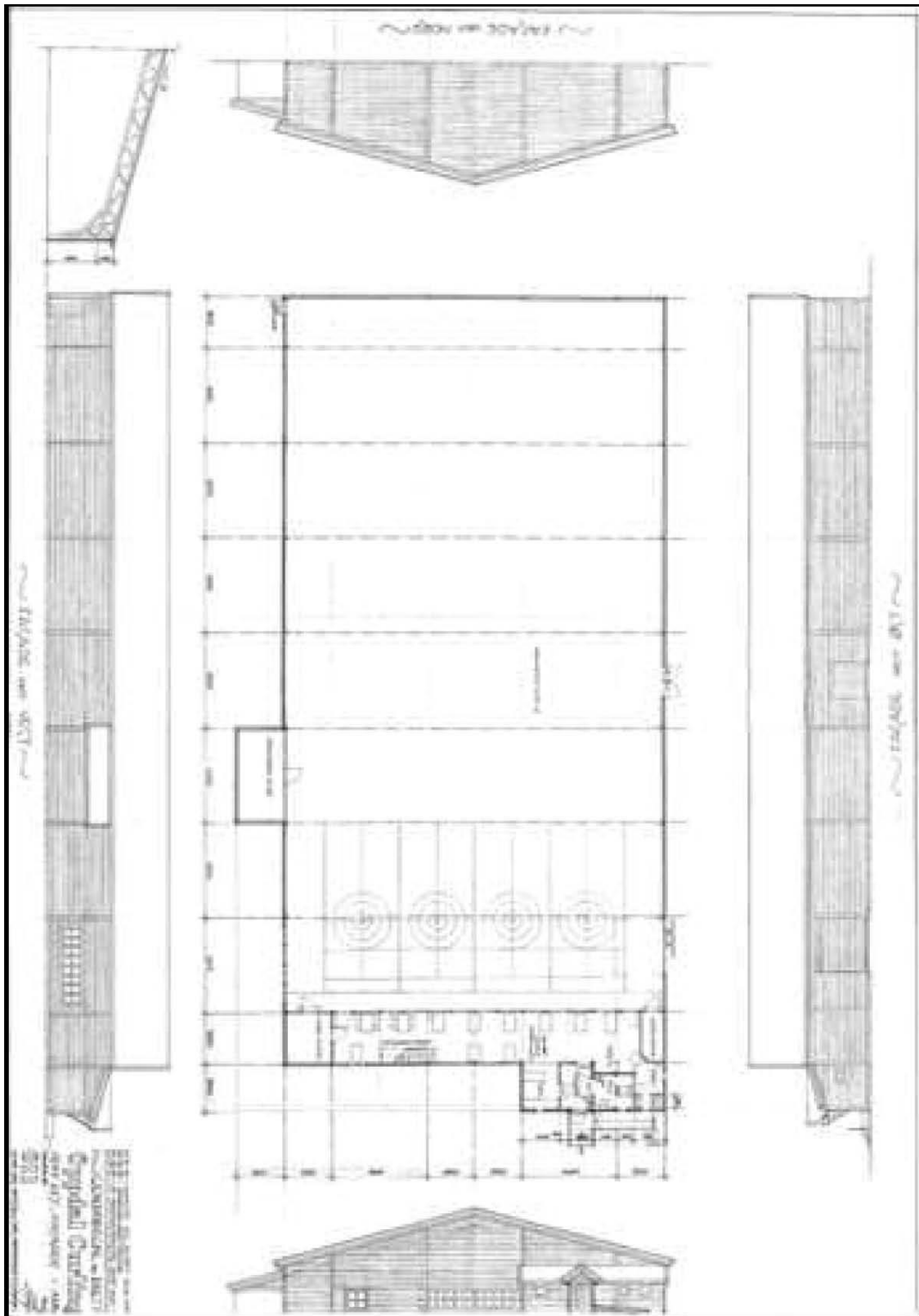

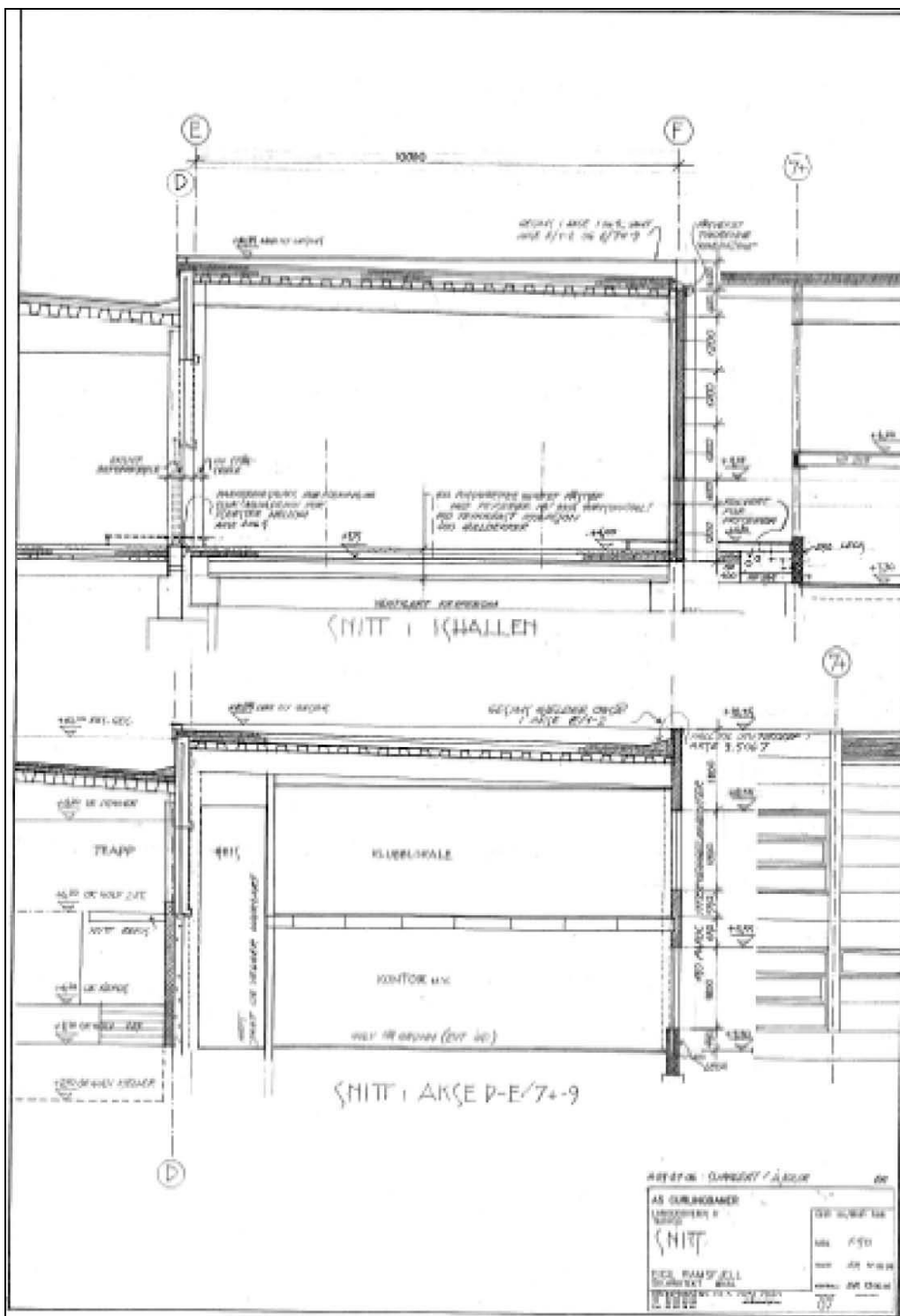

Kilde: Eigil Ramsfjell, Sivilarkitekt MNAL

6. Jar Curling Rink

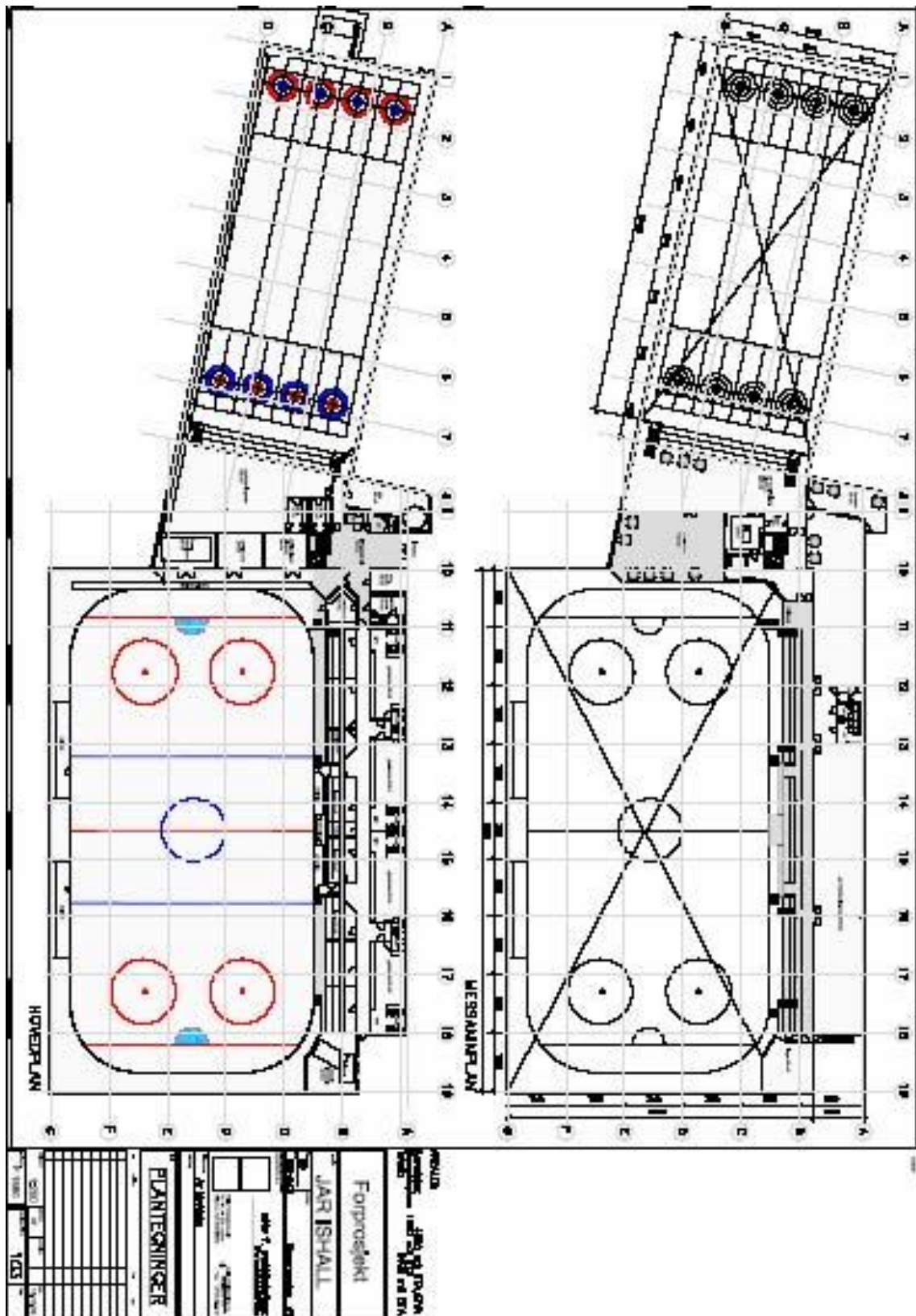

Plan / Section & Exterior

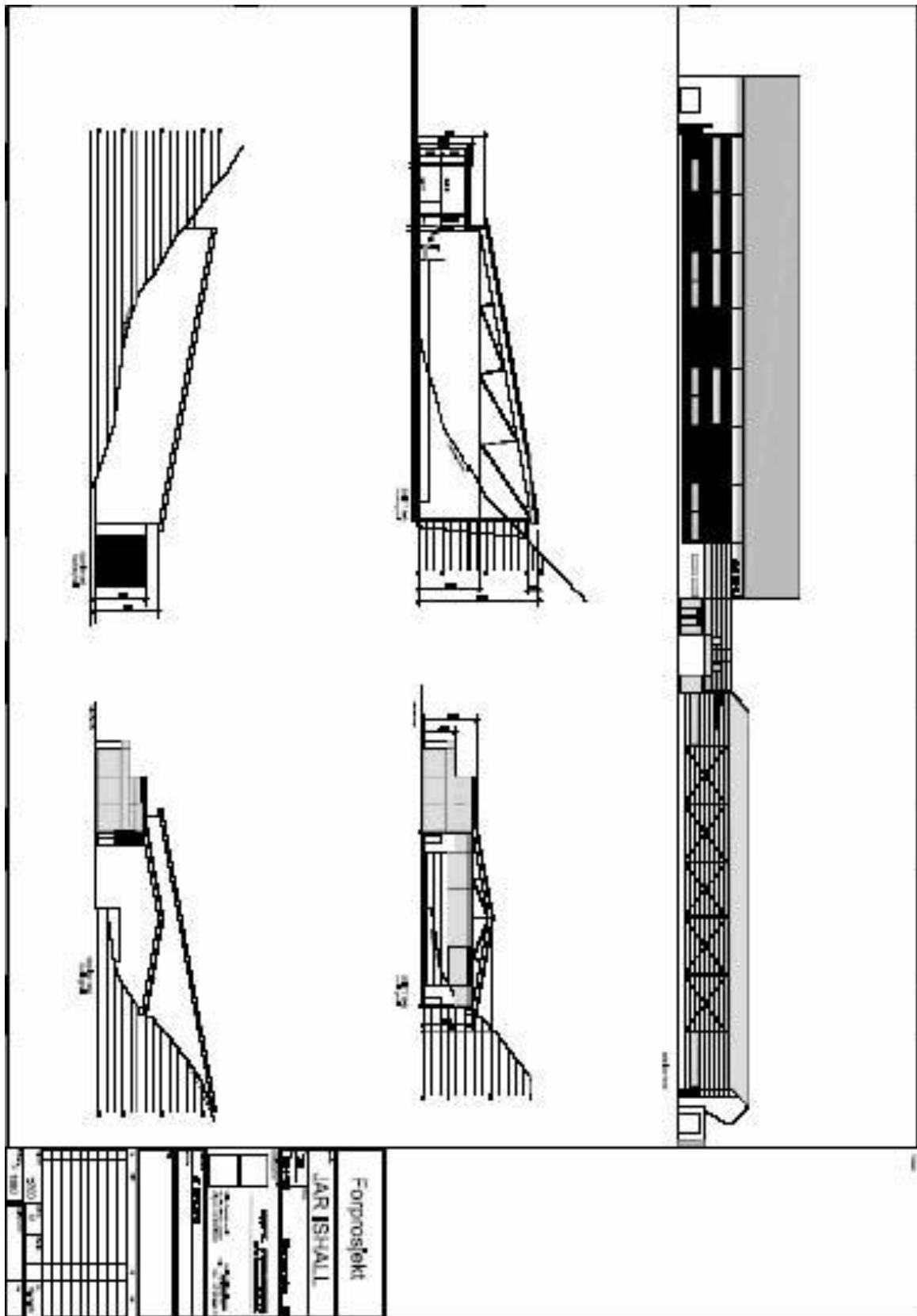



Kilde: Kai T. Fellkjær, Sivilarkitekt MNAL

7. Tårnby Curling Rink (Denmark)

Kilde: Leif Öhman, World Curling Federation

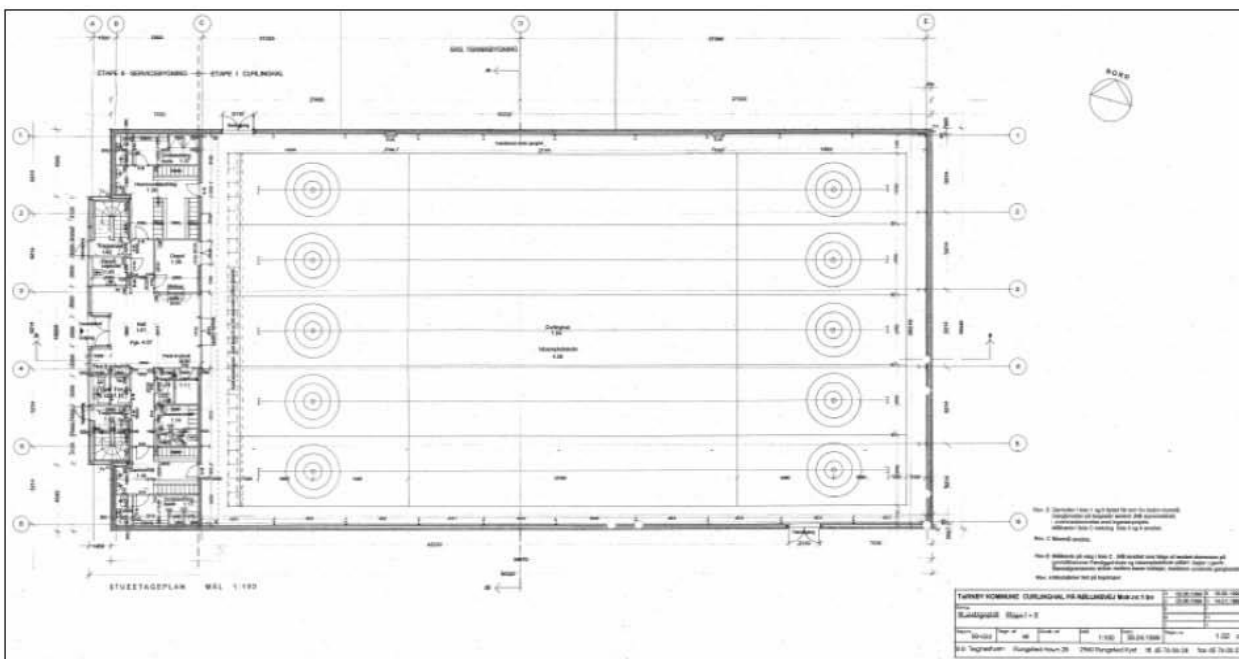
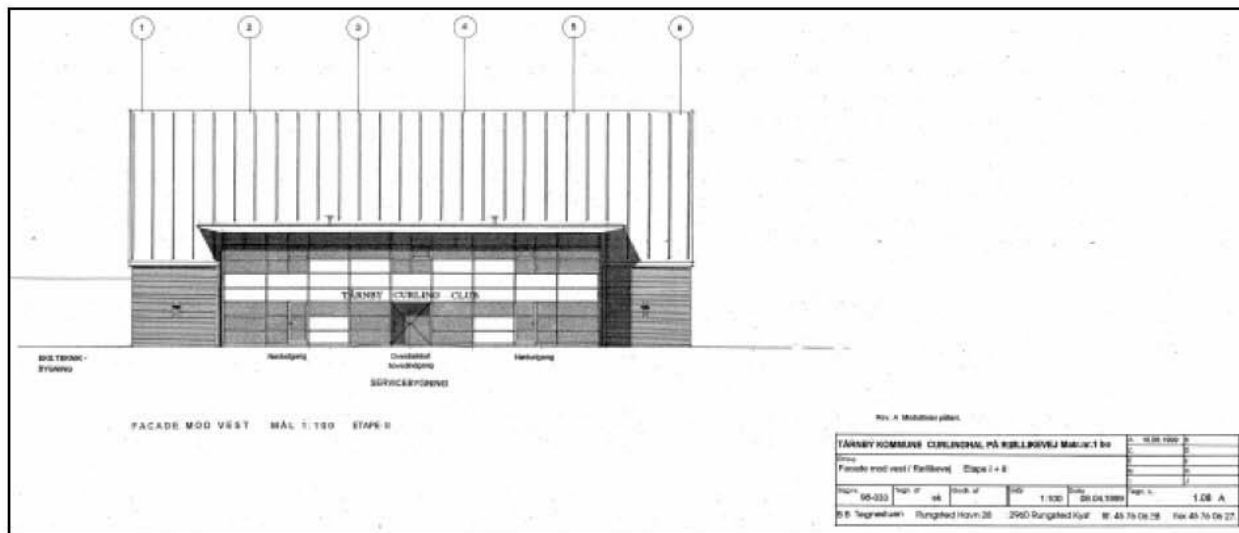

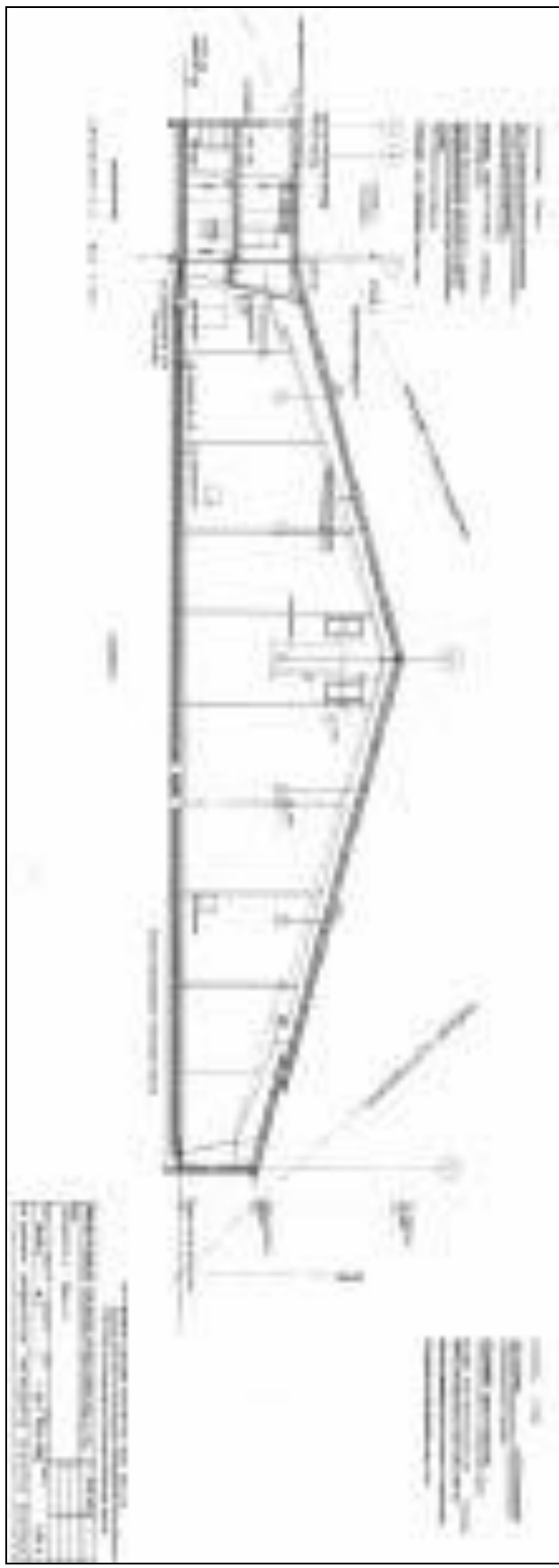

8. Example 6 sheet Rink (Canada)

